

FLASHCUT CNC

CONTROL MADE SIMPLE

®

2.5 Amp Micro Stepping Compact CNC Controller Hardware Guide



Midwest Office

444 Lake Cook Road, Suite 22
Deerfield, IL 60015

Phone (847) 940-9305 ♦ Fax (847) 940-9315
www.flashcutcnc.com

Revised 11/02/2010
© 1998-2010 WPI, Inc.

Table of Contents

1. GETTING STARTED	5
ABOUT THIS MANUAL.....	5
TURNING OFF THE CONTROLLER	5
SAFETY AND USAGE GUIDELINES	6
2. STEPPER CNC CONTROLLER	7
FRONT PANEL.....	7
REAR PANEL	7
3. SYSTEM CONNECTIONS	11
4. REMOVING THE TOP COVER	12
5. SIGNAL GENERATOR	13
INPUT	13
OUTPUT.....	14
JUMPER SETTINGS	15
<i>JP83 – DB to USB Ground</i>	16
<i>JP84/JP85 – Input Power Select</i>	16
<i>JP 86 – USB to Chassis Ground</i>	17
<i>JP 87 – Internal Signal to Chassis Ground</i>	18
INTERNAL CONNECTIONS	18
<i>JP30 – Auxiliary Inputs</i>	19
<i>JP31 – Status LEDs</i>	19
<i>JP32 – Bus Expansion</i>	20
<i>JP33 – Step & Direction</i>	20
<i>JP40 – Input Aux Header</i>	21
<i>JP50 – Output Aux Header</i>	21
<i>JP80 – Rear Panel Power</i>	22
<i>JP81 – Rear Panel Fuse</i>	22
<i>JP82 – Front Panel Switch</i>	22
AXIS PLUG-IN INTERFACES	22
6. MOTOR SIGNAL SETTINGS	24
7. STEPPER MOTOR CABLING	25
MOTOR WIRING FOR OTHER STEPPER MOTORS	26
8. POWER BOARD	28
9. DRIVER MODULE UPGRADES	30
10. APPENDIX	32
SAMPLE WIRING DIAGRAMS	32
<i>Typical Output Line Circuit</i>	32
<i>Typical Input Line Circuit – Internal Power</i>	33
<i>Typical Input Line Circuit – External Power</i>	34
SIGNAL GENERATOR BOARD LAYOUT	36
CONNECTOR PIN-OUT TABLE.....	37
POWER	39
OUTPUTS	40
INPUTS	41
CONNECTORS	42
AXIS PLUG-IN INTERFACE.....	43
11. INTERNAL CONNECTIONS	44
CONNECTION SCHEMATIC	45

1. Getting Started

About This Manual

FlashCut CNC is a unique application involving hardware and software. We recommend that you read all of these instructions before using the product.

Since automated machining is potentially dangerous, please take the time to completely read through this manual and the software User's Guide to understand the operation of the electronics, software and machine before cutting a part.

Turning Off The Controller

Always turn off the CNC Controller when it is not in use.

Safety and Usage Guidelines

When running an automated machine tool, safety is of the utmost importance. For proper and safe use of the FlashCut CNC program and your CNC machine, the following safety guidelines must be followed:

1. Never let the machine tool run unattended.
2. Require any person in the same room as a running machine tool to wear safety goggles, and to stay a safe distance from the machine.
3. Allow only trained operators to run the machine tool. Any operator must have:
 - Knowledge of machine tool operation.
 - Knowledge of personal computer operation.
 - Knowledge of Microsoft Windows.
 - Good common sense.
4. Place safety guards around the machine to prevent injury from flying objects. It is highly recommended that you build a safety shield around the entire tool envelope.
5. Never place any part of your body within the tool envelope while the machine is online, since unexpected machine movement can occur at any time.
6. Always keep the tool envelope tidy and free of any loose objects.
7. Be on alert for computer crashes at all times.

FlashCut CNC, Inc. is not responsible for the safe installation and use of this product. You and only you are responsible for the safety of yourself and others during the operation of your CNC machine tool. FlashCut CNC supplies this product but has no control over how it is installed or used. Always be careful!

FlashCut CNC, Inc. or its affiliates are not responsible for damage to any equipment or workpiece resulting from use of this product.

If you do not understand and agree with all of the above safety guidelines, do not use this product.

2. Stepper CNC Controller

Front Panel

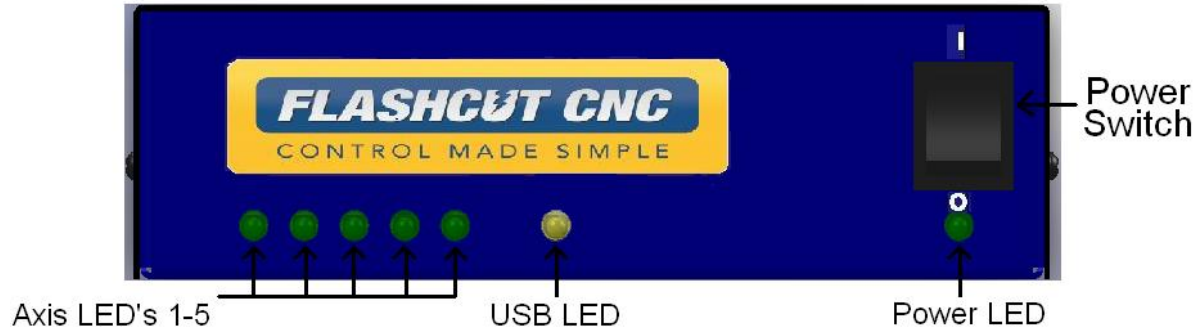

The front panel of the CNC controller has the power switch, the fan and 7 LED's with the following functions:

AXIS LED's 1, 2, 3, 4, 5 – Turns green when the respective axis is moving.

USB LED– Turns yellow when connected to the host PC USB port.

POWER LED– Turns green when the power switch is turned on.

POWER SWITCH – Turns the unit on and off. “I” is on and “O” is off. If there is ever a communications error while running FlashCut CNC, turn the switch off and on to reset the internal microprocessor.

Rear Panel

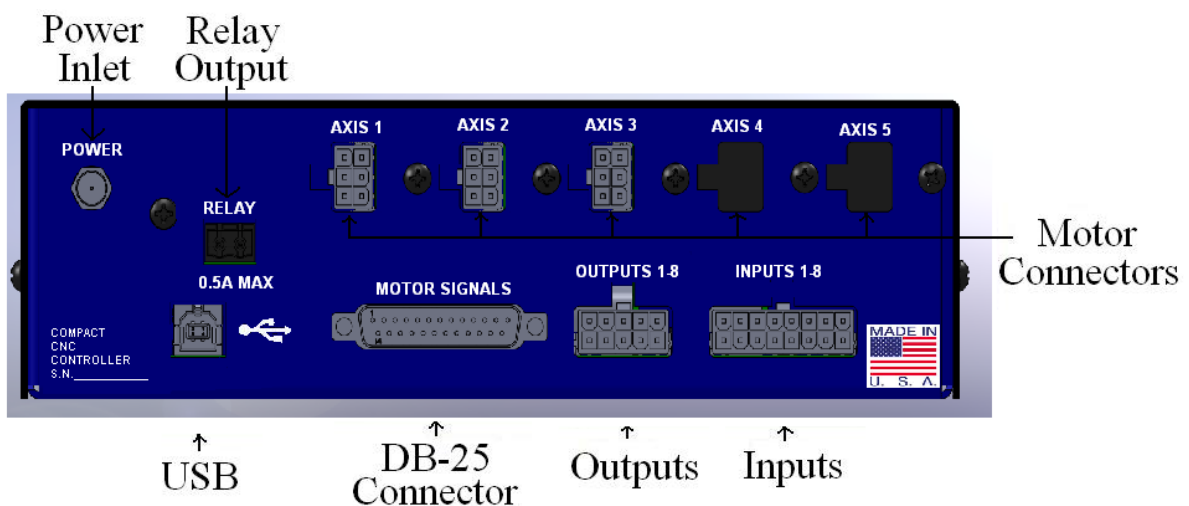

The rear panel has connectors for input and output signals as described below.

POWER INLET – Receptacle for the power supply. The unit is shipped with an external DC power supply. This can be 24-30 VDC and at least 2.5A.

USB – USB connector for communication with the USB port on the host PC. Use a USB-A to B cable with a maximum length of 3 meters to make the connection. For the most robust communication, plug the cable directly into PC, as opposed to a USB repeater or a hub. If the FlashCut software loses communication with the Signal Generator, electrical noise may be the cause. To reduce electrical noise problems, try using a shorter USB cable, or attach one or more ferrite chokes to the USB cable. Toroid-shaped chokes are more effective than snap-on cylindrical chokes. If you need more than 3m of USB cable length, you can use an active extension cable which comes in 4.5m lengths. Note that when running an active extension cable, the USB will run in Full Speed mode.

INPUT – The connector for up to 8 input lines. The most common use of the input lines is for limit or safety switches. These lines are all TTL- and CMOS-compatible optically isolated inputs. When a switch is open, its input signal is high (+5V). When the switch is closed, its input signal is grounded low (0V). If you need more than 8 input lines, an I/O extension board is available.

OUTPUT – The connector for up to 8 output lines. These lines are all compatible with TTL/CMOS level outputs. The Output ports are not setup to drive a 24V external system unless it accepts TTL/CMOS levels. They are all driven by HCT family logic. Output logic high is normally 5V and can go down to 3.9V at full load. Output logic low is normally 0V and can go up to 0.3V at full load. Each of these signals can provide up to 20mA of current. If you need more than 8 output lines, an I/O extension board is available.

RELAY OUTPUT – This connector is a back compatible relay output. Connection should be made in pins 1 and 2 of the 2 pin Phoenix terminal block. Output provides an optically isolated switch closure for controlling both AC and DC devices. Max current loading is 0.5 Amps for this non-polarity sensitive connection.

DB-25 CONNECTOR FOR MOTOR SIGNALS – This uses a DB-25 Cable to send step and direction signals from the FlashCut CNC Signal Generator to an additional external drive box. The pin assignments are as follows:

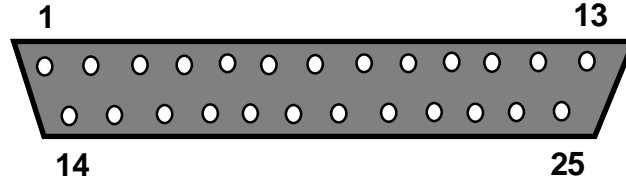

DB25 Pin No.	Signal	DB25 Pin No.	Signal
1	OUTPUT 1	14	ENABLE ALL
2	OUTPUT 2	15	INPUT 1
3	STEP AXIS 5	16	INPUT 2
4	DIRECTION AXIS 5	17	INPUT 3
5	INPUT 5	18	INPUT 4
6	INPUT 6	19	DIRECTION AXIS 4
7	INPUT 7	20	DIRECTION AXIS 3
8	INPUT 8	21	DIRECTION AXIS 2
9	DIRECTION AXIS 1	22	Internal VCC +5V
10	STEP AXIS 4	23	OPT VCC (INPUT)
11	STEP AXIS 3	24	Internal GND
12	STEP AXIS 2	25	OPT GND (INPUT)
13	STEP AXIS 1		

POWER CONNECTOR TO MOTORS – The motors for axes 1-5 plug into these connectors. The motor lines 1-5 are correlated to any combination of the X, Y, Z, A and/or B axes in the Motor Signal Setup menu in the FlashCut CNC software. A cover plate is installed on any unused motor connector for units with less than 5 axes. Each motor connector is a Molex Mini Fit Jr. 6 Pin Receptacle with Male Pins (See Section on Motor Cabling for Mating Connector Information). The pin assignments for the Motor Connector are as follows (looking from the rear of the unit):

Molex Pin	Wire
1	B
2	Cable Ground Shield
3	A
4	B~
5	No Connection
6	A~

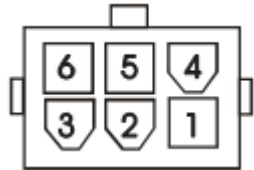

Never connect or disconnect motor cables while the power is on. This will result in damage to the driver box.

The mating motor cable connector is a Molex - Waldom 6-Pin Mini-Fit Jr. Receptacle Housing Part # 39-01-2060 with Female Pins Part # 39-00-0039 or 39-00-0047. Please see the section on Stepper Motor Cabling later in this manual for more information.

3. System Connections

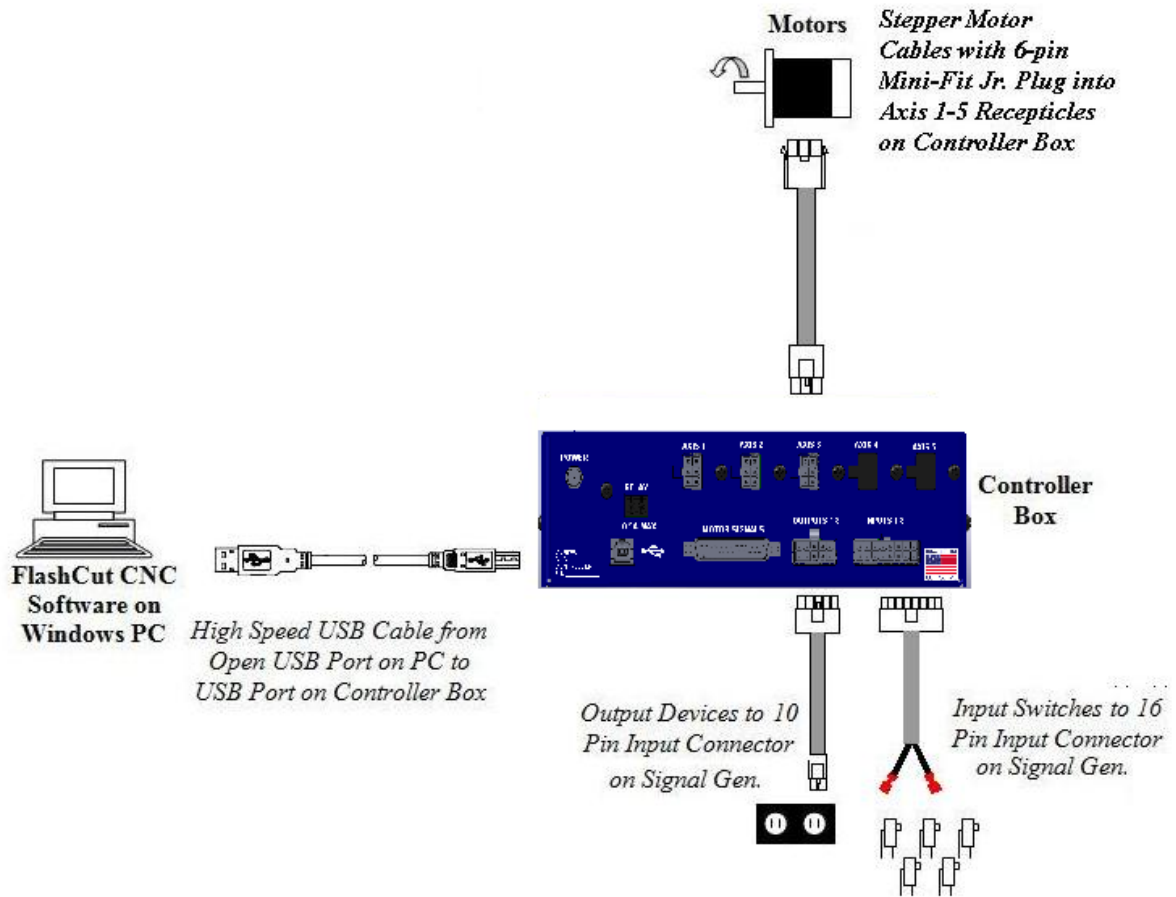

4. Removing the Top Cover

To remove the cover from the unit remove the 4 total screws located on the left and right sides of the unit. Then lift the top cover off.



5. Signal Generator

Input

The default setting for each of the input lines is normally closed (NC). The input line settings can be individually changed between normally closed (NC) or normally open (NO) input lines using FlashCut CNC software. Please refer to the FlashCut CNC User's Guide under "Input Line Settings" for further information.

In the FlashCut CNC software, the Input Line Status dialog displays "OPEN" for a high-level input voltage, or open switch, and "CLOSED" for a low-level input voltage or closed switch.

The input lines are all optically isolated. Jumpers J84 and J85 enable you to choose between the internal power of the Signal Generator and isolated power from an external source. Both jumpers must be set on the same pair of pins (either both must be on pins 1 and 2 (internal) or both must be on pins 2 and 3 (isolated). See the section on "Jumper Settings" for more information.

Internal Power- This is the most convenient option and works well for most applications, but negates some of the signal isolation. When JP84 shorts pins 1 and 2, OPT VCC gets its power from the Internal 5V power source. When JP85 shorts pins 1 and 2, OPT GND is directly connected to the Internal GND.

External Isolated Power

For the best noise immunity, connect an external 5V-24V power supply to the LED side of the optical couplers. When JP84 shorts pins 2 and 3, OPT VCC gets its optically isolated power from the TB-VCC. When JP85 shorts pins 2 and 3, OPT GND is directly connected to the TB-GND.

Choose **only one** of the following methods to supply power:

1. Connect a power source to the TB 40 screw terminal.
2. Connect a power source through pins 23 and 25 of the DB-25 connector.

If you are providing an external voltage through pins 23 and 25 of the DB25 Motor Signal connector or via TB-40, then you must have both JP84 and JP85 jump pins 2 and 3, OTHERWISE SEVERE DAMAGE COULD RESULT.

BE VERY CAREFUL WHEN DOING ANY WIRING. IMPROPER WIRING WILL DAMAGE THE SIGNAL GENERATOR.

Input lines 1, 2, 3 & 4 are also connected through pins 15, 16, 17 & 18 respectively of the Motor Signal connector, and input lines 5, 6, 7 & 8 are also connected through pins 5, 6, 7 & 8 respectively of the Motor Signal connector.

This makes it convenient to send any signals from an external motor driver box, such as limit lines or servo position error signal, back to the Signal Generator through the DB25 cable without using a separate input cable. Note that if an input line is being used through the Motor Signal connector, that line must remain open in the Input connector.

The receptacle that plugs into this connector is a Molex-Waldom Mini-Fit Jr. Series 16 pin receptacle (part number 39-01-2160), with female pins (part number 39-00-0039 or 39-00-0047 for 22 gauge or thinner wires).

The Molex 63811-1000 for 14-24 AWG universal or Molex 11-01-0197 Crimp Tools are recommended for installing the pins. Kits containing connectors and pins are available through FlashCut CNC or an electronics distributor.

The input lines as seen from the back of the box are arranged as follows (all connections denoted by “OPT-GND” are optically isolated ground.):

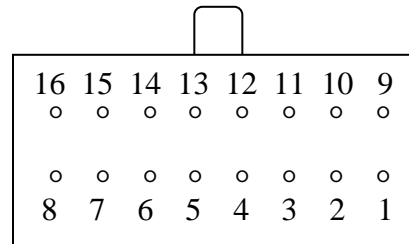

Mini-Fit Jr. Pin No.	Signal	Mini-Fit Jr. Pin No.	Signal
1	OPT-GND	9	INPUT 1
2	OPT-GND	10	INPUT 2
3	OPT-GND	11	INPUT 3
4	OPT-GND	12	INPUT 4
5	OPT-GND	13	INPUT 5
6	OPT-GND	14	INPUT 6
7	OPT-GND	15	INPUT 7
8	OPT-GND	16	INPUT 8

Output

This connector is for up to 8 output lines. These lines are all compatible with TTL/CMOS level outputs. The Output ports are not setup to drive a 24V external system unless it accepts TTL/CMOS levels. They are all driven by HCT family logic. Output logic high is normally 5V and can go down to 3.9V at full load. Output logic low is normally 0V and can go up to 0.3V at full load. Each of these signals can provide up to 20mA of current.

Two additional pins on this connector are provided for your output lines: ground and +5V. These are connected to GND and +5V and are not optically isolated. This 5V circuit can source up to 100 mA. Any larger current demand would require a larger power source.

BE VERY CAREFUL WHEN DOING ANY WIRING. IMPROPER WIRING WILL DAMAGE THE SIGNAL GENERATOR.

The output lines are all initialized to low (0V) when you turn on the Signal Generator. Output lines 1 and 2 are also connected through pins 1 and 2 respectively of the Motor Signal connector. This makes it convenient to connect up to 2 output signals to an external motor driver box to drive devices such as solid-state relays that might be in an external motor driver box.

The receptacle that plugs into this connector is a Molex-Waldom Mini-Fit Jr. Series 10 pin receptacle (part number 39-01-2100), with female pins (part number 39-00-0039 or 39-00-0047 for 22 gauge or thinner wires).

The Molex 63811-1000 for 14-24 AWG universal or Molex 11-01-0197 Crimp Tools are recommended for installing the pins. Kits containing connectors and pins are available through FlashCut CNC or an electronics distributor.

The output lines as seen from the back of the box are arranged as follows:

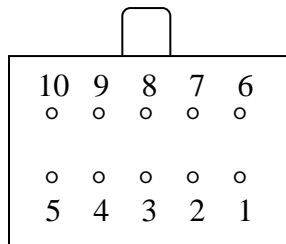

Mini-Fit Jr. Pin No.	Signal	Mini-Fit Jr. Pin No.	Signal
1	OUTPUT 1	6	OUTPUT 2
2	OUTPUT 3	7	OUTPUT 4
3	OUTPUT 5	8	OUTPUT 6
4	OUTPUT 7	9	OUTPUT 8
5	+5V	10	GROUND

Jumper Settings

Pin 1 of all jumpers is indicated by a small white dot printed on the PCB.

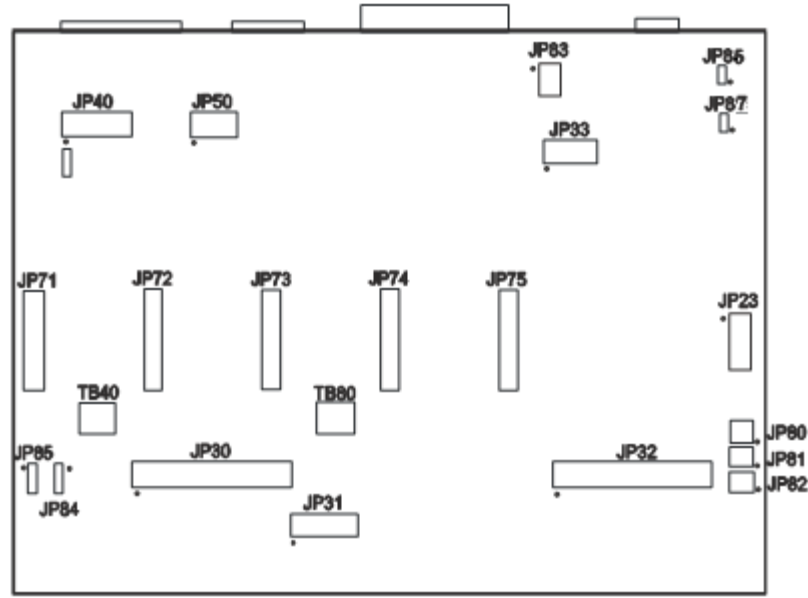

JP83 – DB to USB Ground

This connects the DB 25 ground to the USB ground. By default pins 1 and 2, 3 and 4, and 5 and 6 are jumped as pairs.

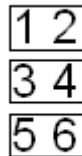

JP84/JP85 – Input Power Select

These two jumpers enable you to choose between the internal power of the Signal Generator and isolated power from an external source. Both jumpers must be set on the same pair of pins (either both must be on pins 1 and 2 or both must be on pins 2 and 3).

Internal Power

This is the most convenient option and works well for most applications, but negates some of the signal isolation. When JP84 shorts pins 1 and 2, OPT VCC gets its power from the Internal 5V power source. When JP85 shorts pins 1 and 2, OPT GND is directly connected to the Internal GND.

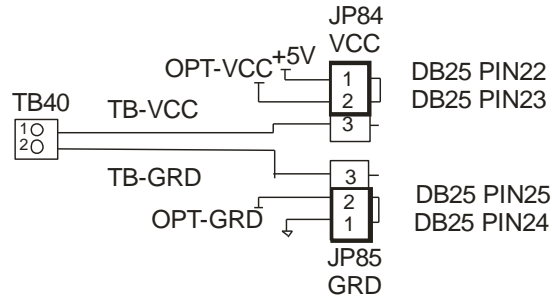

External Isolated Power

For the best noise immunity, connect an external 5V-24V power supply to the LED side of the optical couplers. When JP84 shorts pins 2 and 3, OPT VCC gets its optically isolated power from the TB-VCC. When JP85 shorts pins 2 and 3, OPT GND is directly connected to the TB-GND.

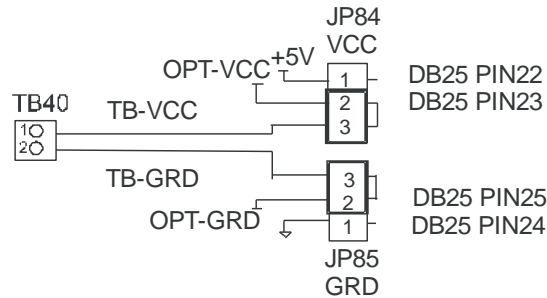

Choose **only one** of the following methods to supply power:

1. Connect a power source to the TB 40 screw terminal.
2. Connect a power source through pins 23 and 25 of the DB-25 connector.
3. Check the resistor value in RP41 to make sure it matches the voltage in TB40.

TB40 Voltage	RP41 Value (10 pin 9 Resistor SIP)
5V	3.9k Ω (Default)
12V	11k Ω
24V	22k Ω

If you are providing an external voltage through pins 23 and 25 of the DB25 Motor Signal connector or via TB-40, then you must have both JP84 and JP85 jump pins 2 and 3, OTHERWISE SEVERE DAMAGE COULD OCCUR.

JP 86 – USB to Chassis Ground

This jumper connects the USB shield to the chassis ground of the Signal Generator when jumped.

JP 87 – Internal Signal to Chassis Ground

This jumper connects the internal signal ground to the chassis ground of the Signal Generator when jumped.

Internal Connections

The diagram below shows the locations of the internal connectors. The top of the diagram corresponds to the back side of the signal generator (where the external connectors are located). The small dot next to some of the connectors designates the number 1 pin position.

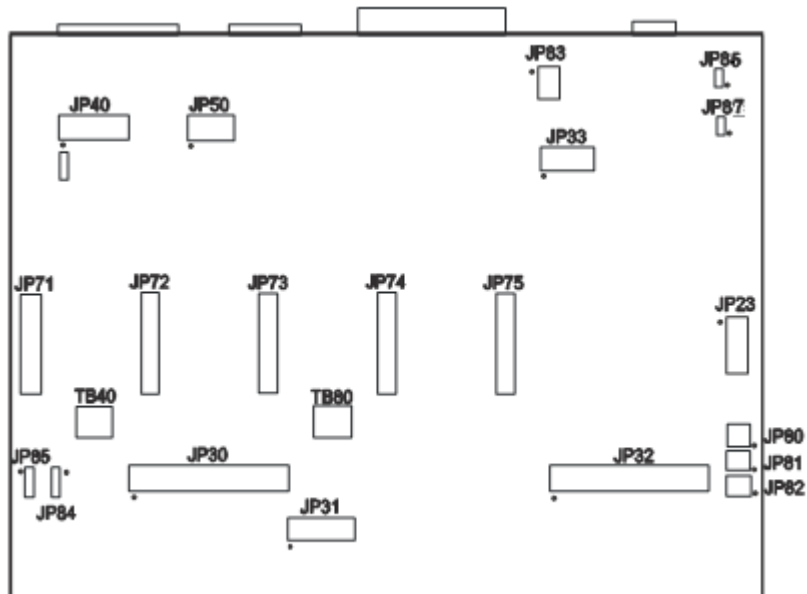

On the following diagrams, the positions of the connectors will be highlighted in black.

Connectors JP30, JP31, JP32, JP33

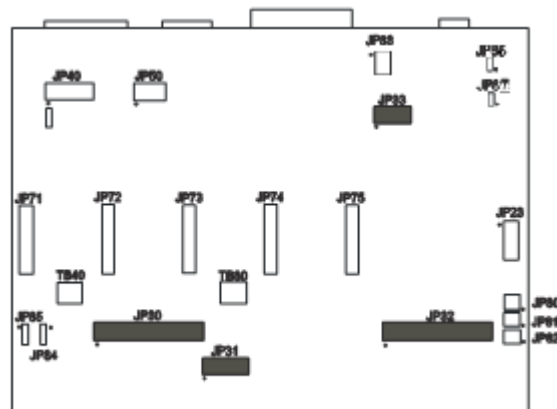

JP30 – Auxiliary Inputs

This contains all of the Input Signals 1-8 which come out of the 501A board and Input Signals 9-32 which come out of the I/O Expansion board.	+3.3V	1	2	+3.3V
	GPI32	3	4	GPI1
	GPI31	5	6	GPI2
	GPI30	7	8	GPI3
	GPI29	9	10	GPI4
	GPI28	11	12	GPI5
	GPI27	13	14	GPI6
	GPI26	15	16	GPI7
	GPI25	17	18	GPI8
	GND	19	20	GND
	GPI24	21	22	GPI9
	GPI23	23	24	GPI10
	GPI22	25	26	GPI11
	GPI21	27	28	GPI12
	GPI20	29	30	GPI13
	GPI19	31	32	GPI14
	GPI18	33	34	GPI15
	GPI17	35	36	GPI16
	+3.3V	37	38	+3.3V
	GND	39	40	GND

JP31 – Status LEDs

This is for connecting wired LEDs from a custom chassis to the 501A LED signals.	+5V	1	2	N/C
	LED-DIR1	3	4	LED-STEP1
	LED-DIR2	5	6	LED-STEP2
	LED-DIR3	7	8	LED-STEP3
	LED-DIR4	9	10	LED-STEP4
	LED-DIR5	11	12	LED-STEP5
	LED-AUX	13	14	LED-USB
	GND	15	16	LED-PWR

JP32 – Bus Expansion

This contains signal and address lines for the I/O Expansion board.	+3.3V	1	2	GND
	CS6	3	4	STATUS6
	TXD2	5	6	FAULT6
	RXD2	7	8	AUX1-STB
	OUT-ENA	9	10	AUX2-STB
	OUT2-STB	11	12	OUT1-STB
	OUT4-STB	13	14	OUT3-STB
	+5V	15	16	+5V
	GND	17	18	GND
	A0	19	20	A1
	DATA1	21	22	DATA2
	DATA3	23	24	DATA4
	DATA8	25	26	DATA7
	DATA6	27	28	DATA5
	+7V	29	30	+7V
	SPHOME	31	32	ENC CLK
	+3.3V	33	34	ENC DIR
	AGND	35	36	AV+
	DAC2	37	38	DAC1
	ADC1	39	40	AGND

JP33 – Step & Direction

This contains all of the step and direction signals for 5 axes of motion.	STEP5	1	2	ENA
	STEP4	3	4	DIR5
	STEP3	5	6	DIR4
	STEP2	7	8	DIR3
	STEP1	9	10	DIR2
	GND	11	12	DIR1

Connectors JP40, JP50

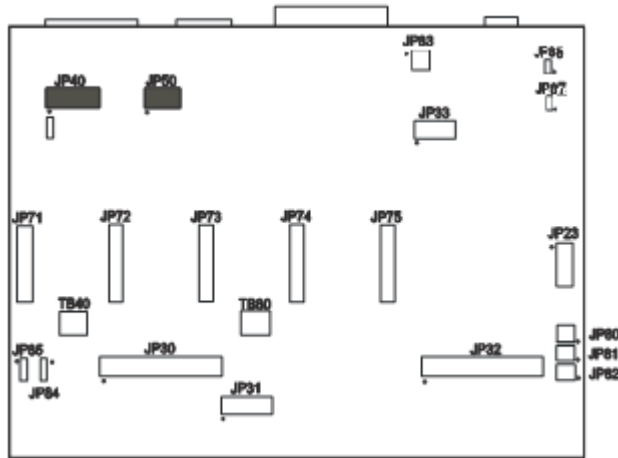

JP40 – Input Aux Header

<p>This contains the same signals as the Mini-Fit Jr. Input Connector. It is provided for the convenience of using a different input connector or an external input connector on a custom chassis.</p>	GPI1	1	2	OPT-GND
	GPI2	3	4	OPT-GND
	GPI3	5	6	OPT-GND
	GPI4	7	8	OPT-GND
	GPI5	9	10	OPT-GND
	GPI6	11	12	OPT-GND
	GPI7	13	14	OPT-GND
	GPI8	15	16	OPT-GND

JP50 – Output Aux Header

<p>This contains the same signals as the Mini-Fit Jr. Input Connector. It is provided for the convenience of using a different input connector or an external input connector on a custom chassis.</p>	GPO2	1	2	GPO1
	GPO4	3	4	GPO3
	GPO6	5	6	GPO5
	GPO8	7	8	GPO7
	GND	9	10	VCC

Connectors JP80, JP81, JP82

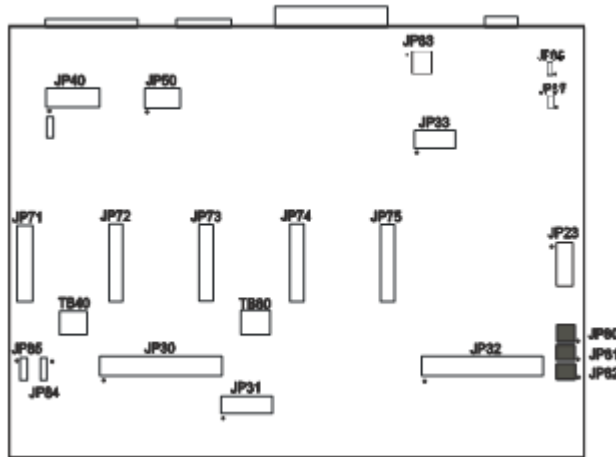

JP80 – Rear Panel Power

Connect the main power here. It can be 8.5V – 16V DC or AC. See current draw chart for power requirements.

JP81 – Rear Panel Fuse

This is for an optional power fuse. The unit is shipped with a shunt instead of a fuse. If you replace the shunt with a fuse, it should be sized according to your power requirements.

JP82 – Front Panel Switch

Connect the main power switch here.

Axis Plug-In Interfaces

Axis Plug-Ins JP71 – JP75

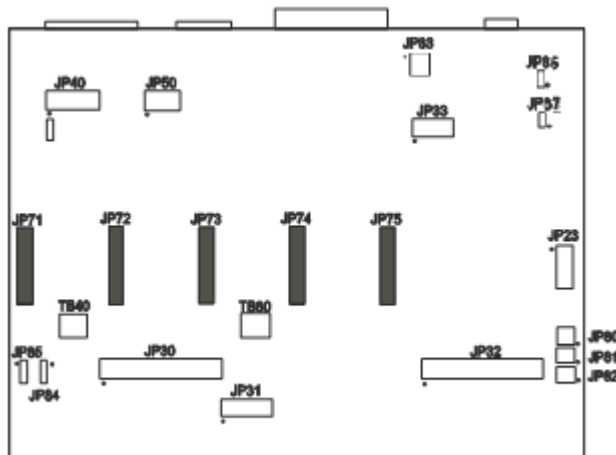

The Axis plug-in interfaces are used to add additional functions to the main signal generator board. For example, a stepper drive plug-in card or cable will enable you to drive a stepper motor directly from the signal generator box.

1	2
3	4
5	6
7	8
9	10
11	12
13	14
15	16
17	18
19	20

Each of these plug-in cards is a SKT10X2 connector, with the pin configuration on the left. Pin numbers 1-5, 7, 13, 15 and 17-20 perform the same function on each jumper.

Per the chart below, pins 6, 8-12, 14 and 16 have different values of Status, Fault, InputA, Dir, InputB, Step, SCOM and CS respectively for each plug-in card.

Pin No.	Label	Function	JP-71	JP-72	JP-73	JP-74	JP-75
1	HV-PWR	High Voltage Power	HV-PWR	HV-PWR	HV-PWR	HV-PWR	HV-PWR
2	HV-PWR	High Voltage Power	HV-PWR	HV-PWR	HV-PWR	HV-PWR	HV-PWR
3	GND	Ground	GND	GND	GND	GND	GND
4	GND	Ground	GND	GND	GND	GND	GND
5	RxD2	Serial Com. Receive	RxD2	RxD2	RxD2	RxD2	RxD2
6	STATUS	Status	STATUS1	STATUS2	STATUS3	STATUS4	STATUS5
7	TxD2	Serial Com. Transmit	TxD2	TxD2	TxD2	TxD2	TxD2
8	FAULT	Fault Indicator	FAULT1	FAULT2	FAULT3	FAULT4	FAULT5
9	INPUTA	Input A	IN8	IN10	IN12	IN14	IN16
10	DR	Direction	DR1	DR2	DR3	DR4	DR5
11	INPUTB	Input B	IN9	IN11	IN13	IN15	IN17
12	ST	Step	ST1	ST2	ST3	ST4	ST5
13	SM0	SM0	SM0	SM0	SM0	SM0	SM0
14	SCOM	SCOM	SCOM1	SCOM2	SCOM3	SCOM4	SCOM5
15	SM1	SM1	SM1	SM1	SM1	SM1	SM1
16	CS	Chip Select	CS1	CS2	CS3	CS4	CS5
17	ENA	Enable	ENA	ENA	ENA	ENA	ENA
18	+5V	+5V	+5V	+5V	+5V	+5V	+5V
19	GND	GND	GND	GND	GND	GND	GND
20	GND	Ground	GND	GND	GND	GND	GND

6. Motor Signal Settings

The motor settings in the Motor Signal Setup Screen in the FlashCut CNC software need to be properly set according to the driver box that you have. Please refer to Motor Signal Setup section of the User's Guide for the best way to set up your drive for your software version.

For this drive, the best signals are as follows:

Driver Model: 2.5A Compact Micro Stepper (5501-X-25-M)

Step Pulse: High

Step Pulse Width: 2

Min. Time Between Steps: 2

Direction-Step Setup: 2

Min. Step-Direction Lag: 2

Enable Signal Polarity: High

7. Stepper Motor Cabling

Motor Cable - 2 Twisted pair (one pair for A coil and one pair for B Coil) 22 gauge and shielded (18 gauge for 6A motors). Shield is only connected to noted pin on Molex-Waldom connector and should not be connected to motor end. Use Belden - M 8723 CM 2PR22 Shielded Cable or equivalent.

Connector - Molex - Waldom 6-Pin Mini-Fit Jr.
Receptacle Housing Part # 39-01-2060.
Female Pins Part # 39-00-0039 or 39-00-0047

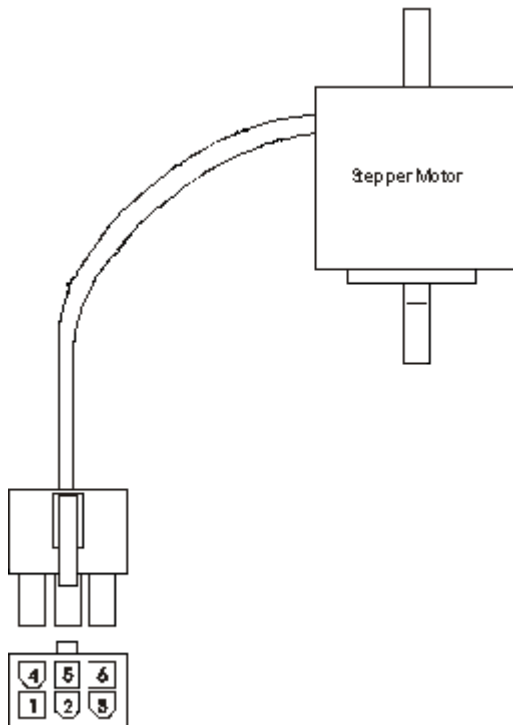

Molex Pin	Motor Wire
1	B
2	Cable Ground Shield
3	A
4	B~
5	No Connection
6	A~

Motor Wiring for Other Stepper Motors

If you have your own stepper motor, you can use the following charts for your wiring. Note that the motor wire colors will vary.

6 Lead Motor – ½ Coil Bipolar

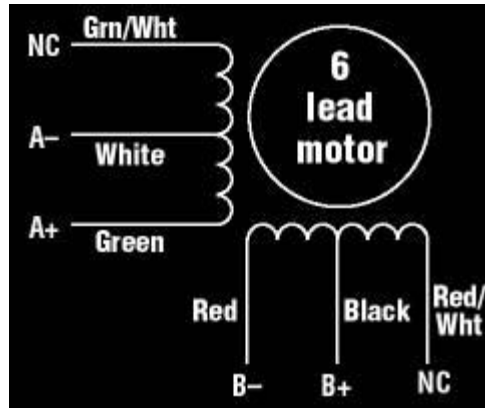

6 Lead Motor – Series Bipolar

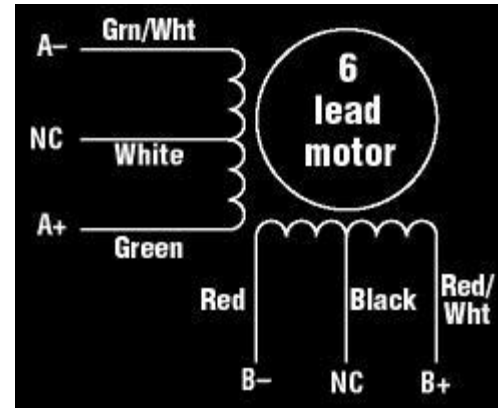

8 Lead Motor – Parallel Bipolar

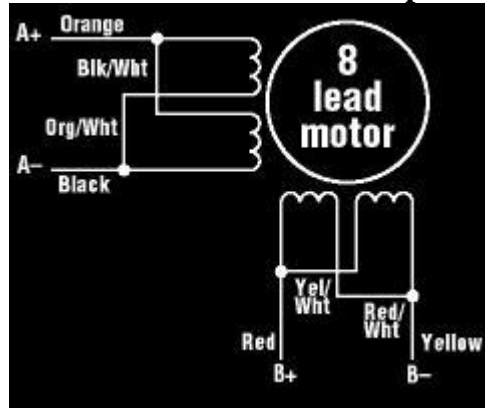

8 Lead Motor – Series Bipolar

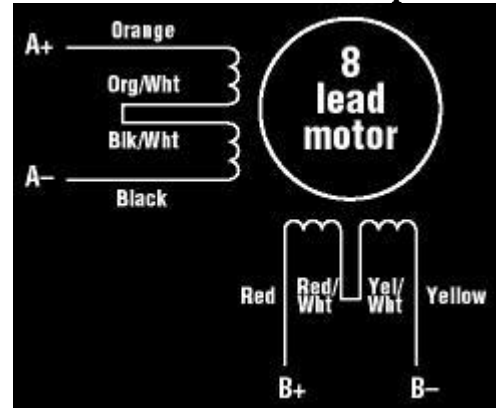

Unknown Motor Wiring

If you are uncertain which is the A pair and which is the B pair, you can use an ohm meter and the following chart to determine the pairs (and the center taps on a 6-wire motor)

A to A~	About 1-10 ohms (Equal to B to B~)
B to B~	About 1-10 ohms (Equal to A to A~)
A or A~ to B or B~	No Continuity
A Center to A or A~	½ the resistance of A to A~
B Center to B or B~	½ the resistance of B to B~
B Center to A or A~	No Continuity
A Center to B or B~	No Continuity

If the A and A~ or the B and B~ are reversed, the motor will spin the opposite direction. This can easily be corrected by changing the motor polarity in the Setup...Motor Settings menu in the FlashCut CNC software.

8. Power Board

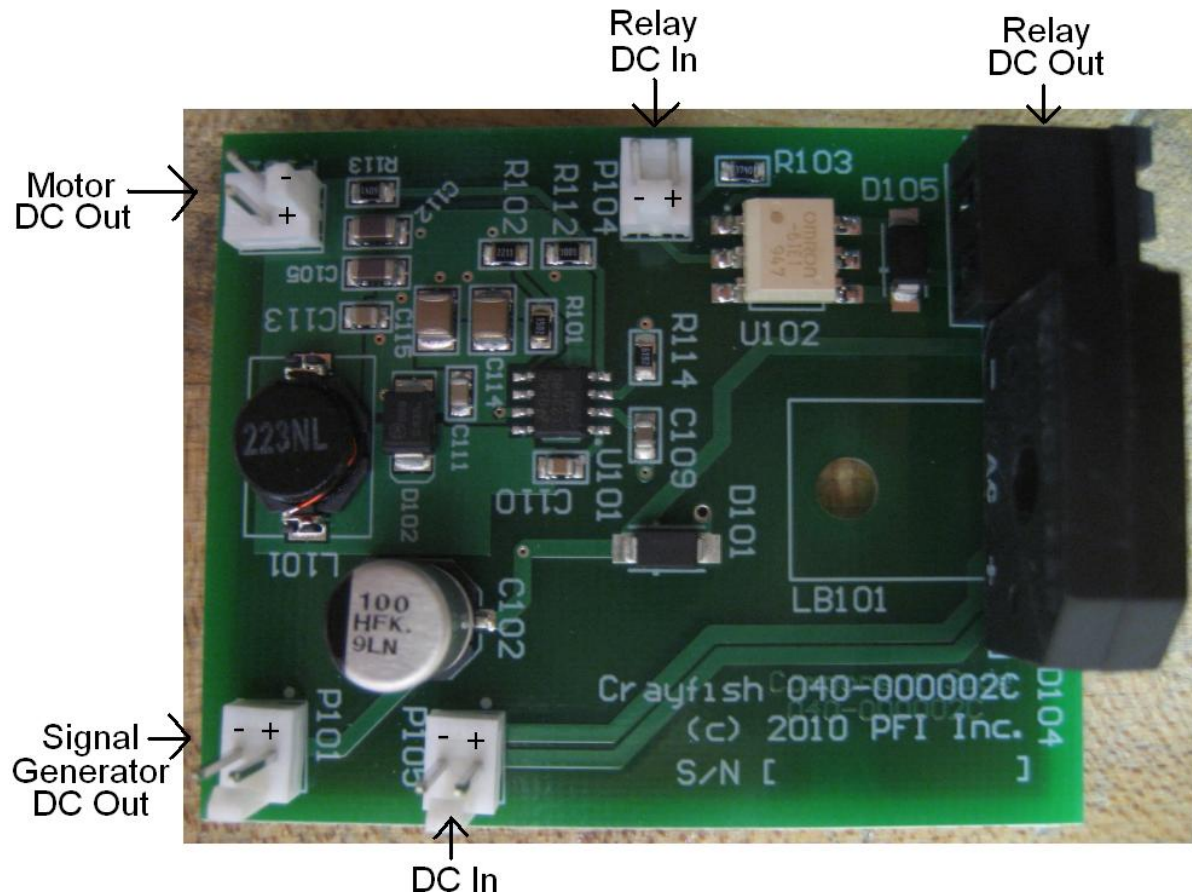

The function of the Power Board is to supply DC voltage to the drive modules as well as the logic signals to the Signal Generator. A schematic can be found in the Appendix

DC IN- This input receives a 24-30 VDC signal from the power supply connected to the back of the CNC controller.

SIGNAL GENERATOR DC OUT- This output sends a 9 VDC signal to power the Signal Generator. When viewing the power board in the configuration above the top contact of the signal generator DC output is positive and the bottom contact is negative.

MOTOR DC OUT- This output provides a 24-30 VDC signal to power up to 5 drive modules

RELAY DC IN- This input receives a DC signal from the signal generator when output 1 is activated in the FlashCut CNC software. This output can be used to turn on and off devices connected to the relay DC out.

RELAY DC OUT- This output sends a DC signal to turn on and off devices that are controlled by opening and closing a circuit that draws 0.5A or less.

9. Driver Module Upgrades

To upgrade your CNC controller such as adding a 4th or 5th axis you should install the new drive module(s) using the following instructions.

Improper wiring can cause damage to your driver box and/or motors. Please take care in following these instructions properly. Please refer to the drawings below for the correct logic connectors.

1. Open the drive box.
2. Remove any axis cover plate covering the axis you are adding.
3. Place drive module on signal generator board.

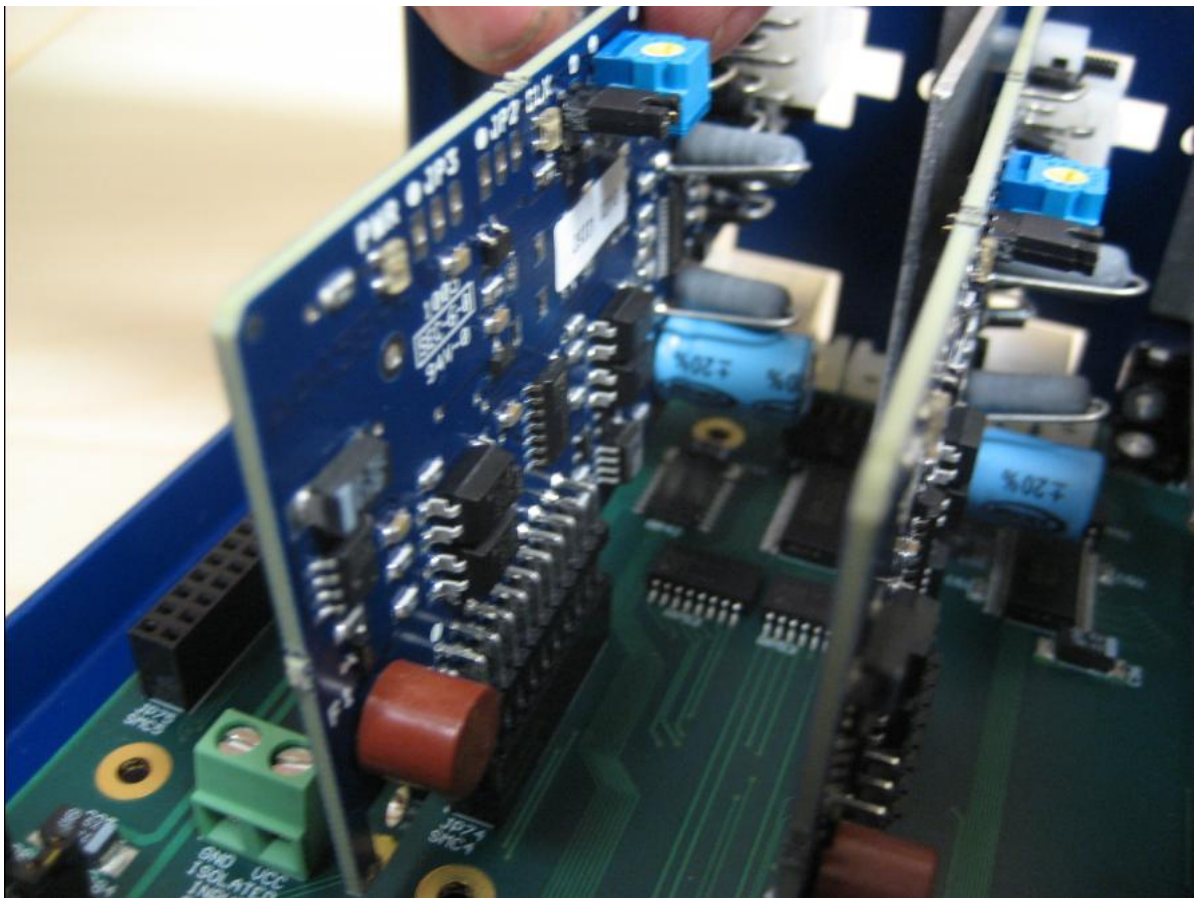

4. Mount the drive module to the driver box chassis using (1) #6 X ¼ self tapping screw.



5. Replace the drive box cover.

10. Appendix

Sample Wiring Diagrams

Typical Output Line Circuit

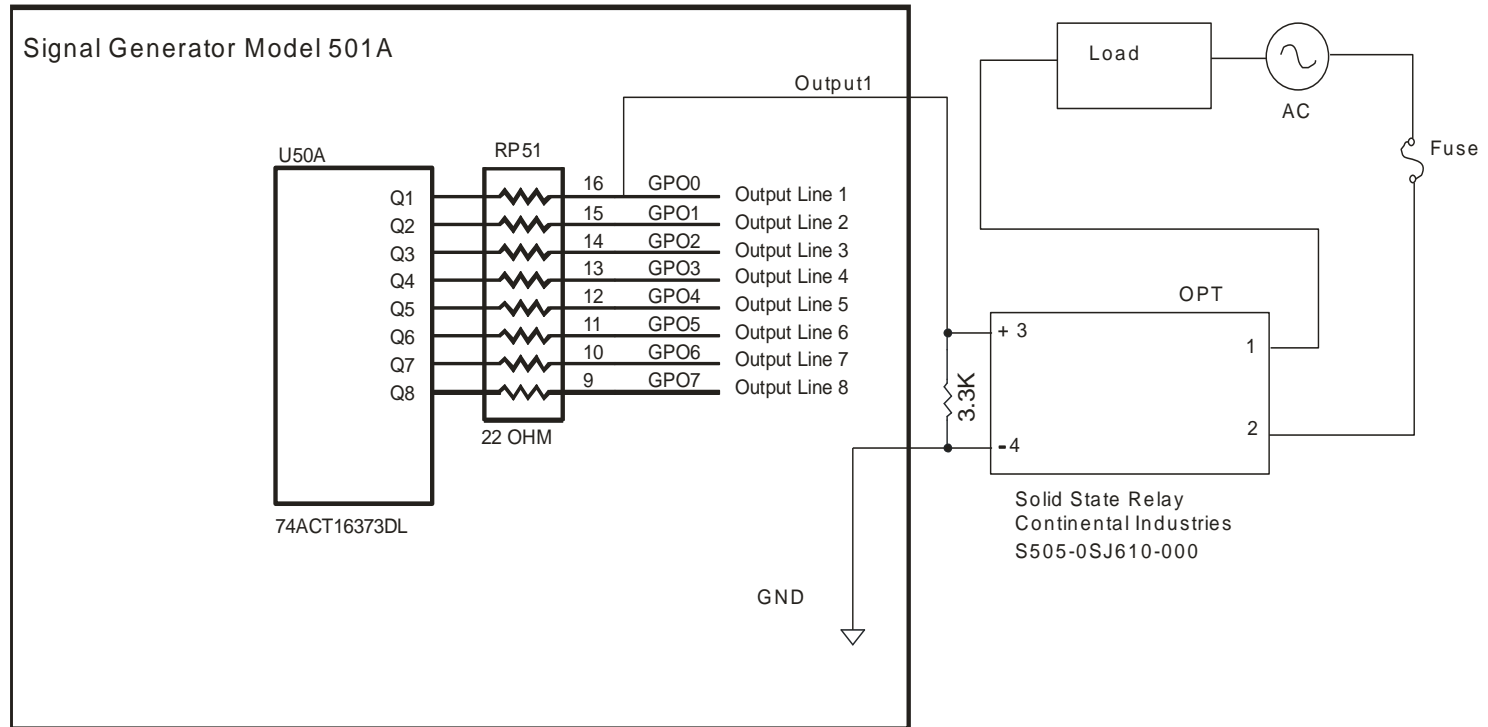

The above schematic shows a typical connection of one solid state relay controlled by output line 1 of the Signal Generator. A typical load would be a spindle, a vacuum, a laser, etc. In this example, the solid-state relay used is a Continental Industries model S505-0SJ610-000. It takes a 3 to 32VDC input and has an output of 24-330VAC.

Each of the output signals has a 22-ohm resistor in series with their outputs. This is to reduce any “ringing” at the transient switching points. Ground and 5V are provided on this connector for your convenience. The FlashCut Spindle On/Off Relay Box is wired as shown in the above schematic.

Typical Input Line Circuit – Internal Power

Signal Generator Model 501 A

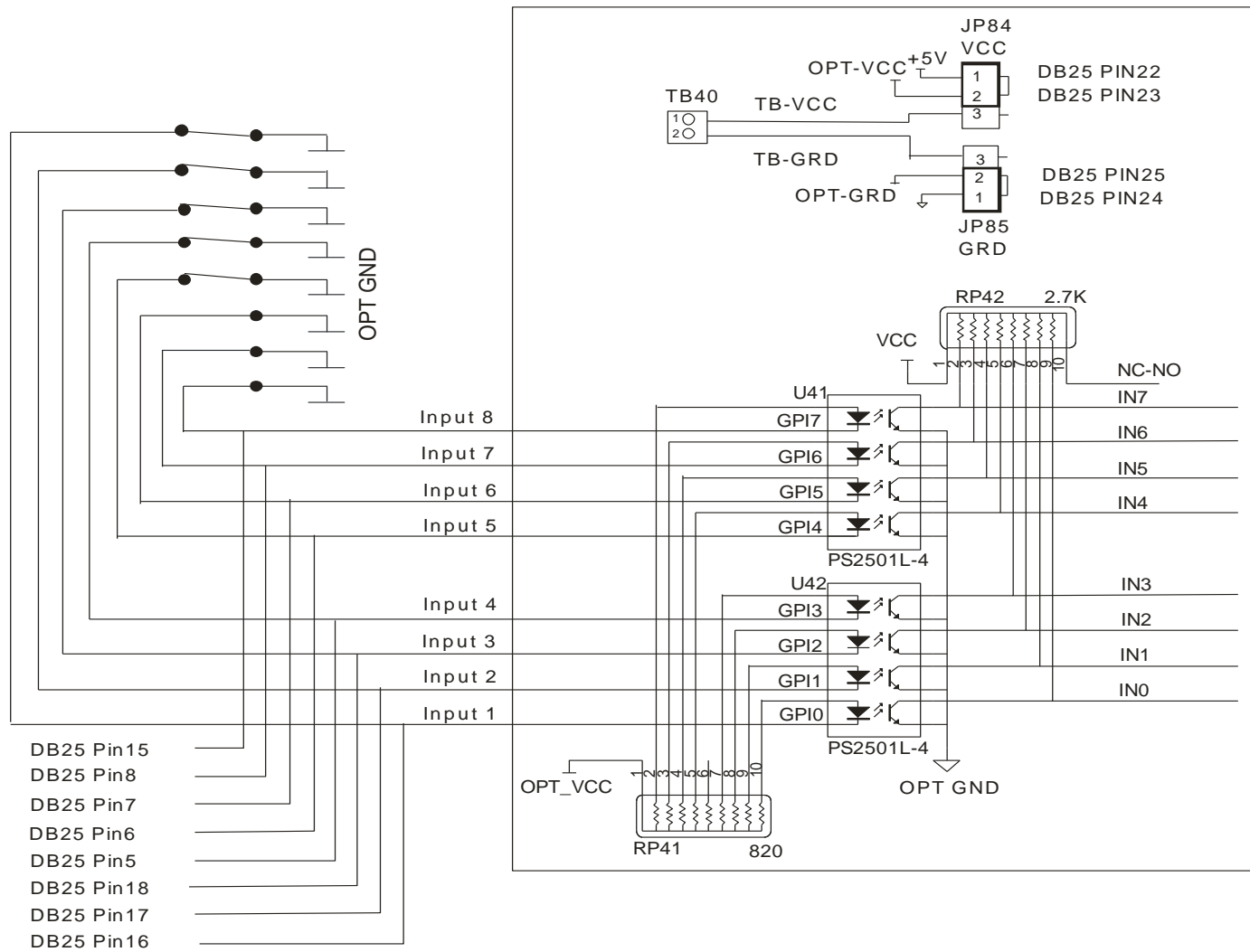

Typical Input Line Circuit – External Power

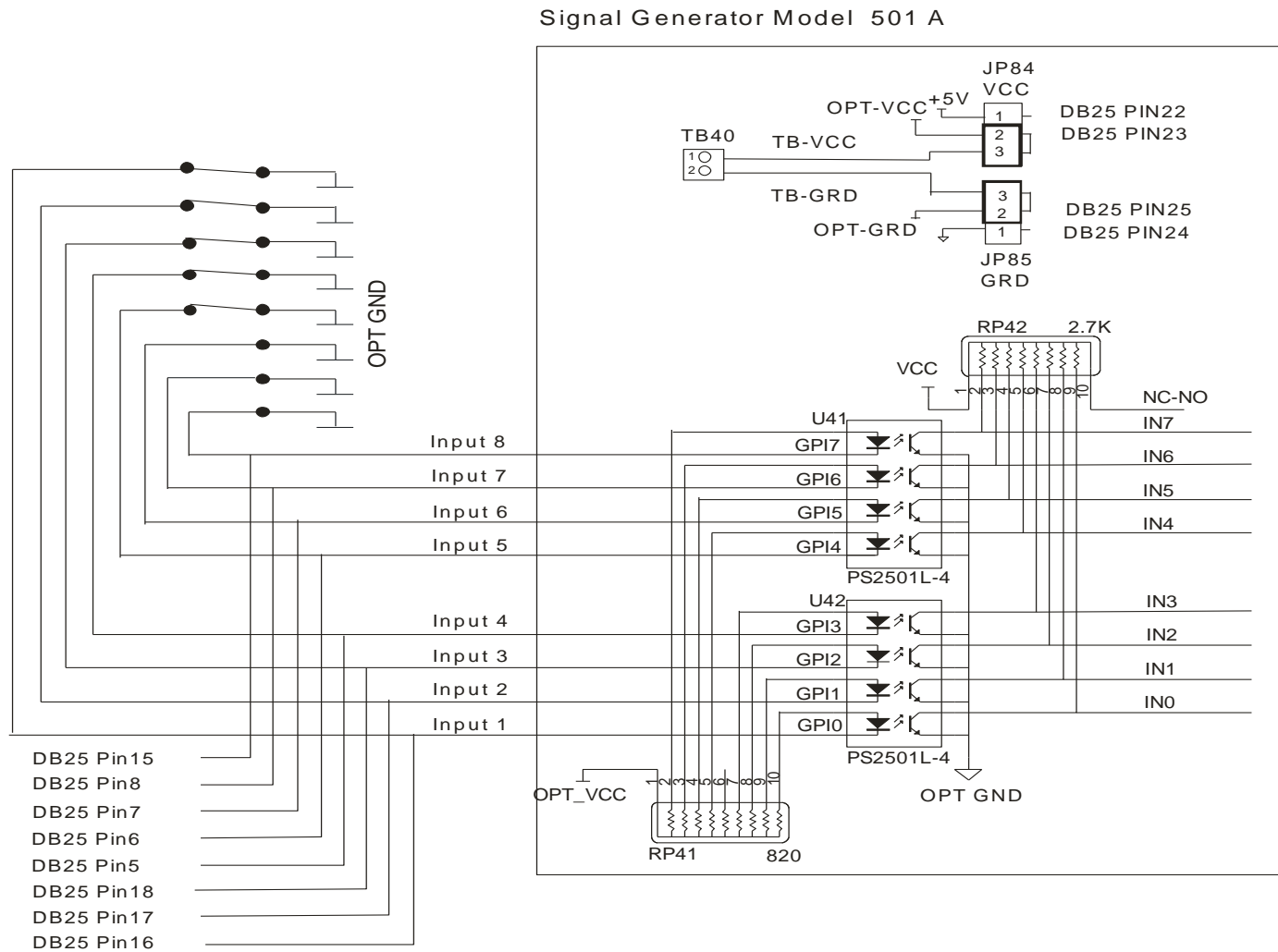

The above schematic shows a typical connection of 5 normally closed switches. These switches are connected between input lines 1-5 and ground. Lines 6-8 are connected directly to ground with jumper wires. All external connections shown are made through the Input connector on the back of the Signal Generator. This resistor pack (RP41) is socketed so that you can change the value if needed for your application.

The input lines are all optically isolated. In this example, JP84 and JP85 are shorted using the internal power to source the external side of the optical couplers. However, for the best isolation, JP84 and JP85 should be open, and power should be provided through pins 23 and 25 of the DB25 Motor Signal connector. Input lines 1-4 and 5- 8 are internally connected to pins 15-18 and 5-8 respectively of the DB25 Motor Signal connector.

Note that the FlashCut CNC limit switch kit has the same wiring as shown in this example.

Signal Generator Board Layout

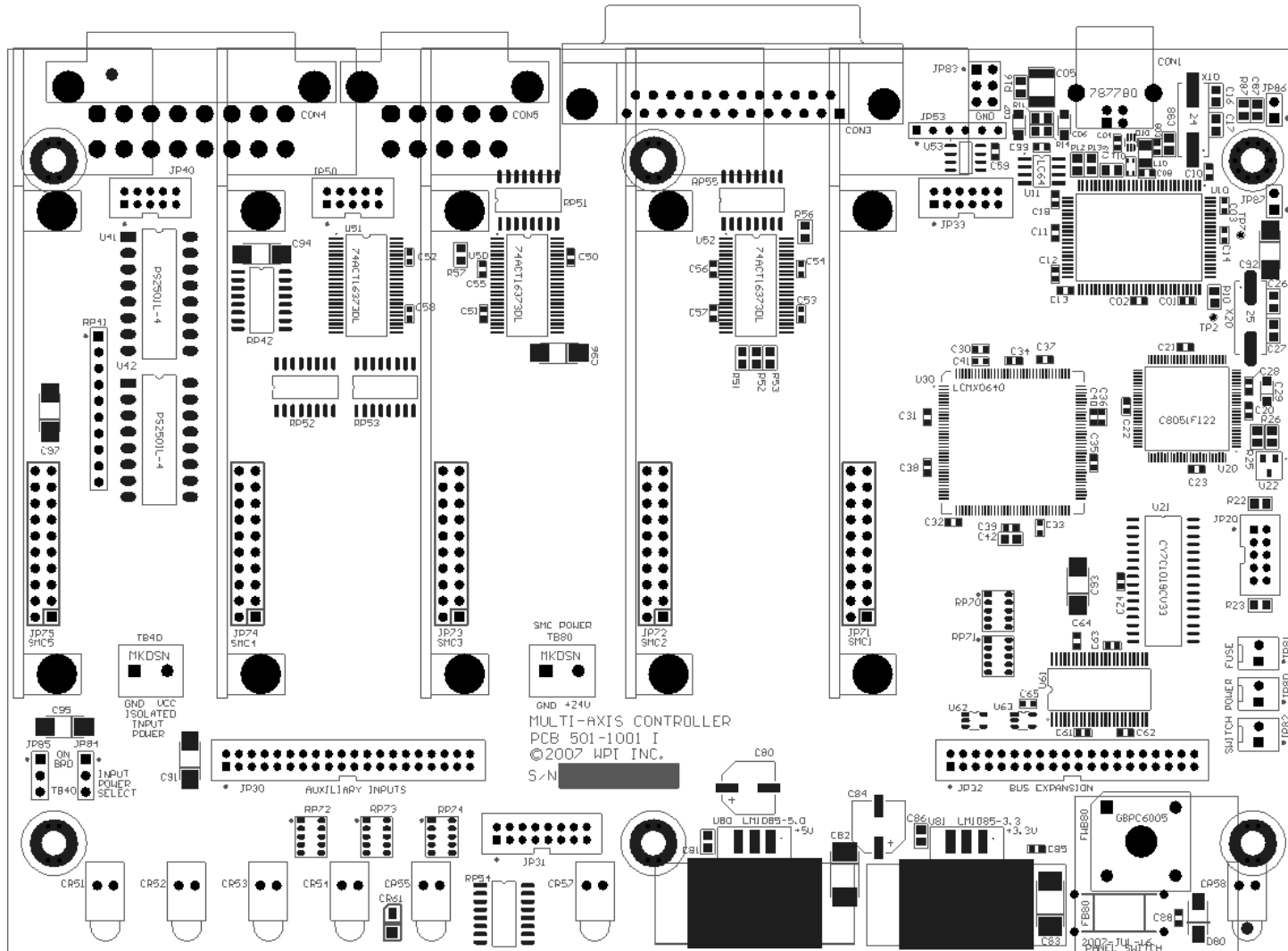

Connector Pin-Out Table

EXTERNAL CONNECTORS (RED)**CON1: STANDARD USB TYPE-A****CON3 – DB25F**

GPO1	1	14	ENA
GPO2	2	15	GPI1
STEP5	3	16	GPI2
DIR5	4	17	GPI3
GPI5	5	18	GPI4
GPI6	6	19	DIR4
GPI7	7	20	DIR3
GPI8	8	21	DIR2
DIR1	9	22	VCC
STEP4	10	23	OPT-VCC
STEP3	11	24	GND
STEP2	12	25	OPT-GND
STEP1	13		SHIELD

CON4 - INPUTS

OPT-GND	1	9	GPI1
OPT-GND	2	10	GPI2
OPT-GND	3	11	GPI3
OPT-GND	4	12	GPI4
OPT-GND	5	13	GPI5
OPT-GND	6	14	GPI6
OPT-GND	7	15	GPI7
OPT-GND	8	16	GPI8

CON5 - OUTPUTS

GPO1	1	6	GPO2
GPO3	2	7	GPO4
GPO5	3	8	GPO6
GPO7	4	9	GPO8
VCC	5	10	GND

INTERNAL CONNECTORS (ORANGE)

PIN 1 OF ALL HEADERS IS INDICATED BY A SMALL WHITE DOT PRINTED ON THE PCB.

JP30 – AUXILIARY INPUTS

2 X 20 - 2MM SPACING

+3.3V	1	2	+3.3V
GPI32	3	4	GPI1
GPI31	5	6	GPI2
GPI30	7	8	GPI3
GPI29	9	10	GPI4
GPI28	11	12	GPI5
GPI27	13	14	GPI6
GPI26	15	16	GPI7
GPI25	17	18	GPI8
GND	19	20	GND
GPI24	21	22	GPI9
GPI23	23	24	GPI10
GPI22	25	26	GPI11
GPI21	27	28	GPI12
GPI20	29	30	GPI13
GPI19	31	32	GPI14
GPI18	33	34	GPI15
GPI17	35	36	GPI16
+3.3V	37	38	+3.3V
GND	39	40	GND

JP31 – STATUS LEDS

2 X 8 - 2MM SPACING

+5V	1	2	N/C
LED-DIR1	3	4	LED-STEP1
LED-DIR2	5	6	LED-STEP2
LED-DIR3	7	8	LED-STEP3
LED-DIR4	9	10	LED-STEP4
LED-DIR5	11	12	LED-STEP5
LED-AUX	13	14	LED-USB
GND	15	16	LED-PWR

INTERNAL CONNECTORS (ORANGE)**JP32 – BUS EXPANSION**

2 X 20 - 2MM SPACING

+3.3V	1	2	GND
CS6	3	4	STATUS6
TXD2	5	6	FAULT6
RXD2	7	8	AUX1-STB
OUT-ENA	9	10	AUX2-STB
OUT2-STB	11	12	OUT1-STB
OUT4-STB	13	14	OUT3-STB
+5V	15	16	+5V
GND	17	18	GND
A0	19	20	A1
DATA1	21	22	DATA2
DATA3	23	24	DATA4
DATA8	25	26	DATA7
DATA6	27	28	DATA5
+7V	29	30	+7V
SPHOME	31	32	ENC CLK
+3.3V	33	34	ENC DIR
AGND	35	36	AV+
DAC2	37	38	DAC1
ADC1	39	40	AGND

JP33 – STEP & DIRECTION

2 X 6 - 2MM SPACING

STEP5	1	2	ENA
STEP4	3	4	DIR5
STEP3	5	6	DIR4
STEP2	7	8	DIR3
STEP1	9	10	DIR2
GND	11	12	DIR1

INTERNAL CONNECTORS (ORANGE)**JP40 – INPUT AUX HEADER**

2 X 8 - 2MM SPACING

GPI1	1	2	OPT-GND
GPI2	3	4	OPT-GND
GPI3	5	6	OPT-GND
GPI4	7	8	OPT-GND
GPI5	9	10	OPT-GND
GPI6	11	12	OPT-GND
GPI7	13	14	OPT-GND
GPI8	15	16	OPT-GND

JP50 – OUTPUT AUX HEADER

2 X 5 - 2MM SPACING

GPO2	1	2	GPO1
GPO4	3	4	GPO3
GPO6	5	6	GPO5
GPO8	7	8	GPO7
GND	9	10	VCC

JP53 – OUT 1&2 LOW SIDE DRIVER

1 X 6 - 2MM SPACING

+5V VCC	1
CLAMP for GP02	2
GPO2 Low Side Driver	3
GPO1 Low Side Driver	4
CLAMP for GP01	5
LOGIC GND	6

JP80 - REAR PANEL POWER**JP81 - REAR PANEL FUSE****JP82 - FRONT PANEL SWITCH****CONFIGURATION JUMPERS (BLUE)**

PIN 1 OF ALL JUMPERS IS INDICATED BY A SMALL WHITE DOT PRINTED ON THE PCB.

JP83: DB TO USB GROUND

ALWAYS LEAVE PIN 1 JUMPED TO PIN 2, PIN3 JUMPED TO PIN 4 AND PIN 5 JUMPED TO PIN 6 UNLESS DIRECTED OTHERWISE BY FLASHCUT TECH SUPPORT.

JP84/JP85: INPUT POWER SELECT

SHOULD BE JUMPED THE SAME WAY...

1-2: INPUTS DRIVEN BY ON-BOARD VCC

2-3: INPUTS BIASED BY VOLTAGE ON TB40

JP86: USB GROUND

SHOULD BE JUMPED TO PULL USB GROUND TO CHASSIS GROUND

JP87: CHASSIS GROUND

SHOULD BE JUMPED TO PULL INTERNAL SIGNAL GROUND OF THE SIGNAL GENERATOR TO CHASSIS GROUND.

TERMINAL BLOCKS (GREEN)**TB40: ISOLATED INPUT POWER**

VOLTAGE APPLIED HERE BIASES INPUTS IF JP84/JP85 ARE SHORTED PINS 2-3; DO NOT EXCEED 5V ON THIS TERMINAL UNLESS SPECIFICALLY ARRANGED WITH FLASHCUT TECH SUPPORT.

TB80: SMC POWER (24V)

APPLY 24 VDC HERE TO BIAS THE STEPPER MOTOR CONTROLLER BOARD(S) PLUGGED INTO SLOTS SMC1-SMC5

Power

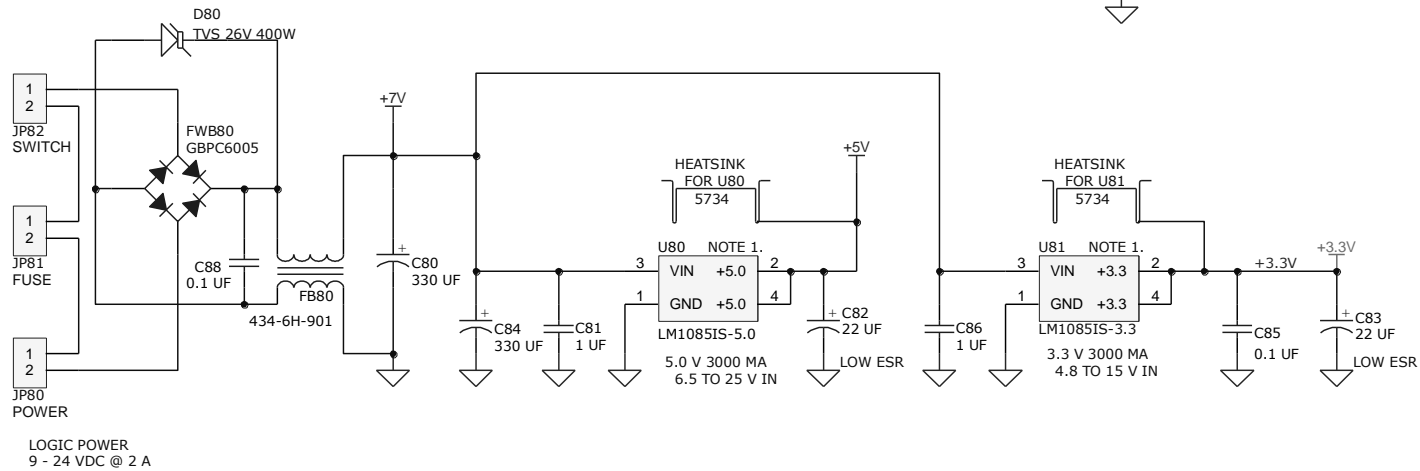
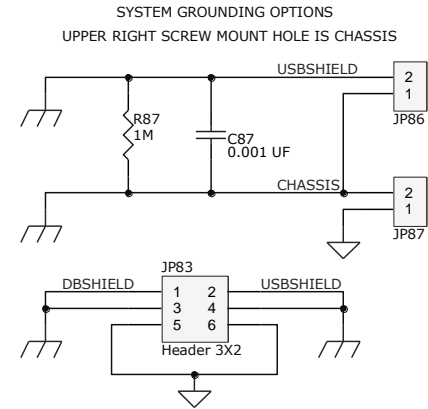
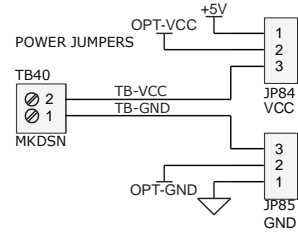
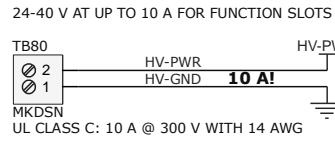

Outputs

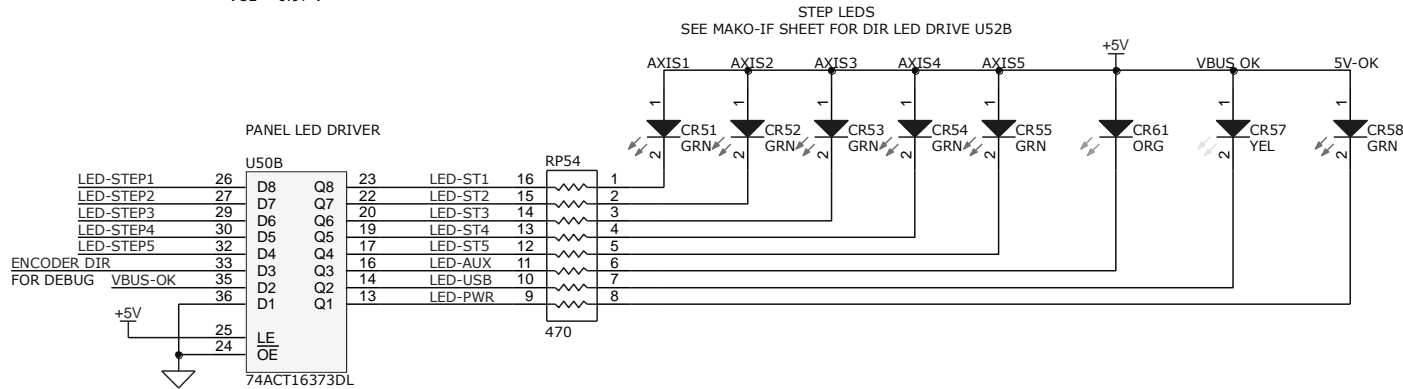
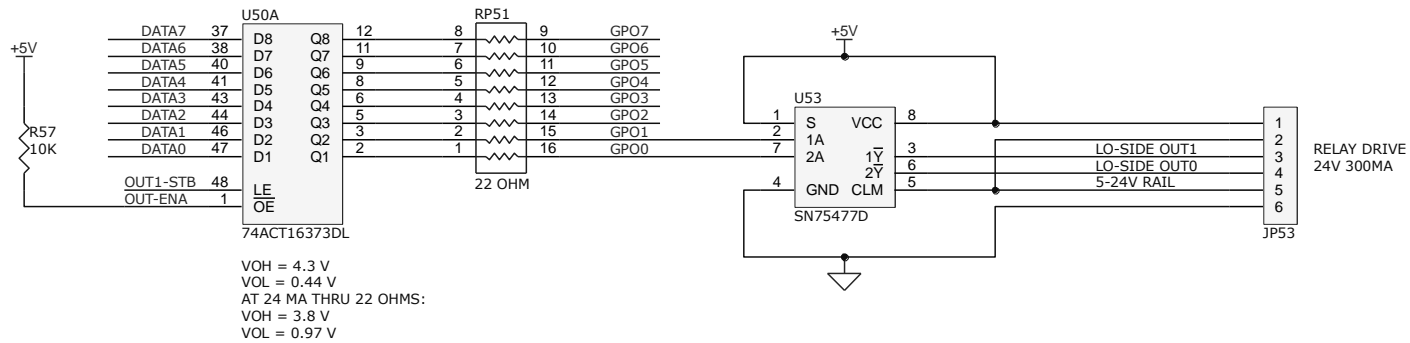

Inputs

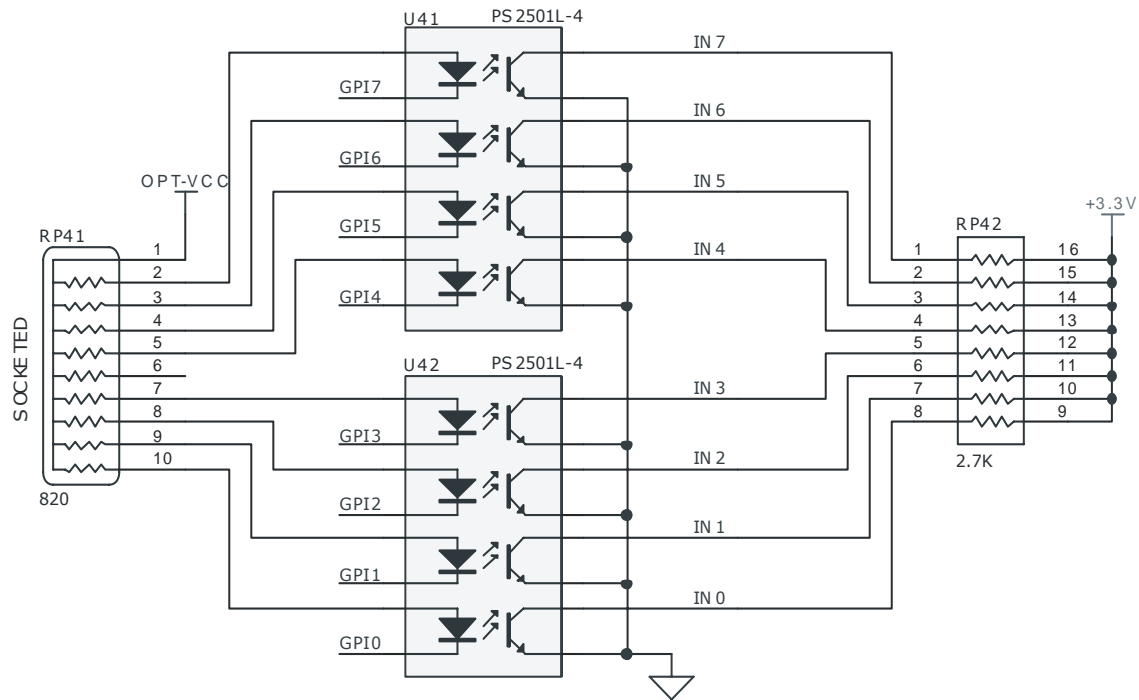

Connectors

INPUT AUX HEADER

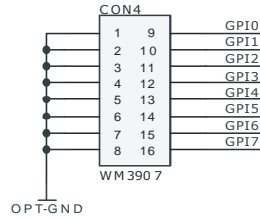
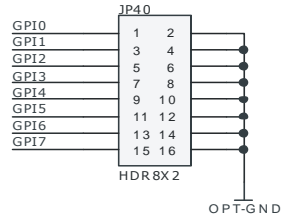

PINOUTS ARE FOR 1:1 MAPPING TO MINI-FIT JR.

OUTPUT AUX HEADER

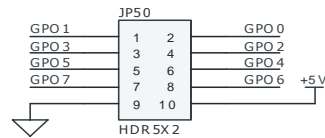

BACK PANEL MINI-FIT JR. S

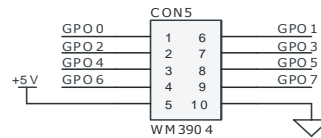

STATUS LE DS (GEMVISION)

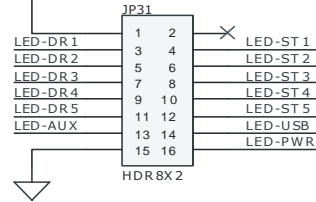

SEE USB.SCHDOC FOR USB CONNECTOR 1X4

SEE POWER.SCHDOC FOR PWR & SHIELDING JUMPERS HV & 5V TERMINAL BLOCKS

SEE MAKO-IFSCHDOC FOR MAKO HEADERS 2X 10 (5 EA)

SEE MCU.SCHDOC FOR JTAG HEAD ER 2X5

STEP & DIR (GEMVISION)

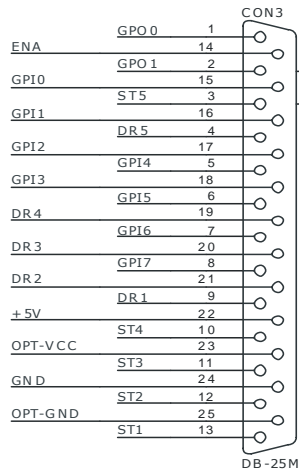
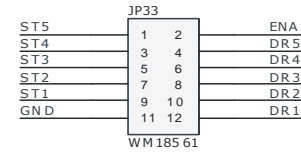

DB -25M

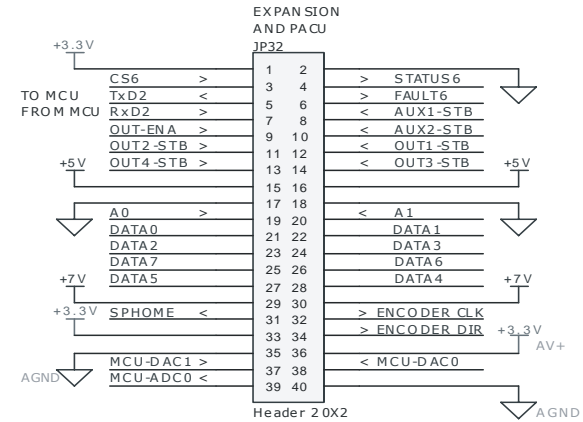
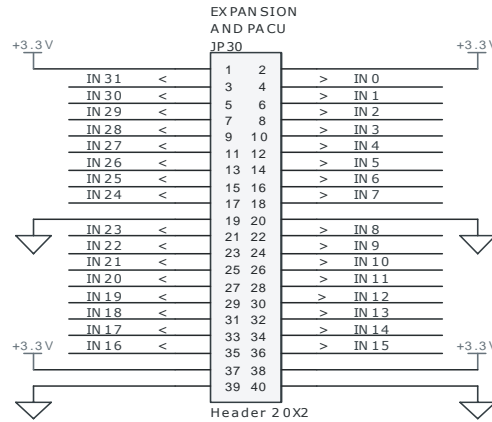

Axis Plug-In Interface

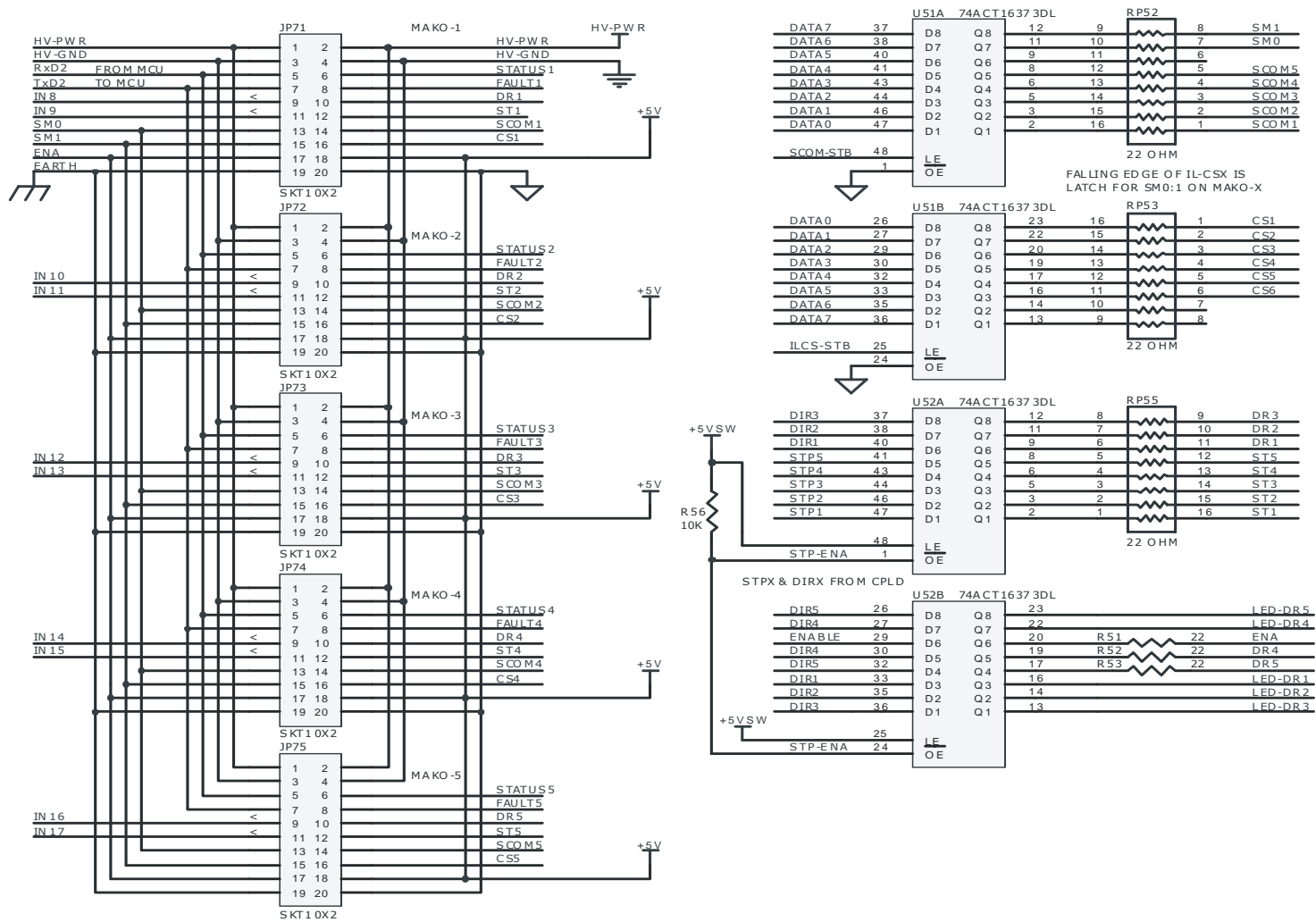

11. Internal Connections

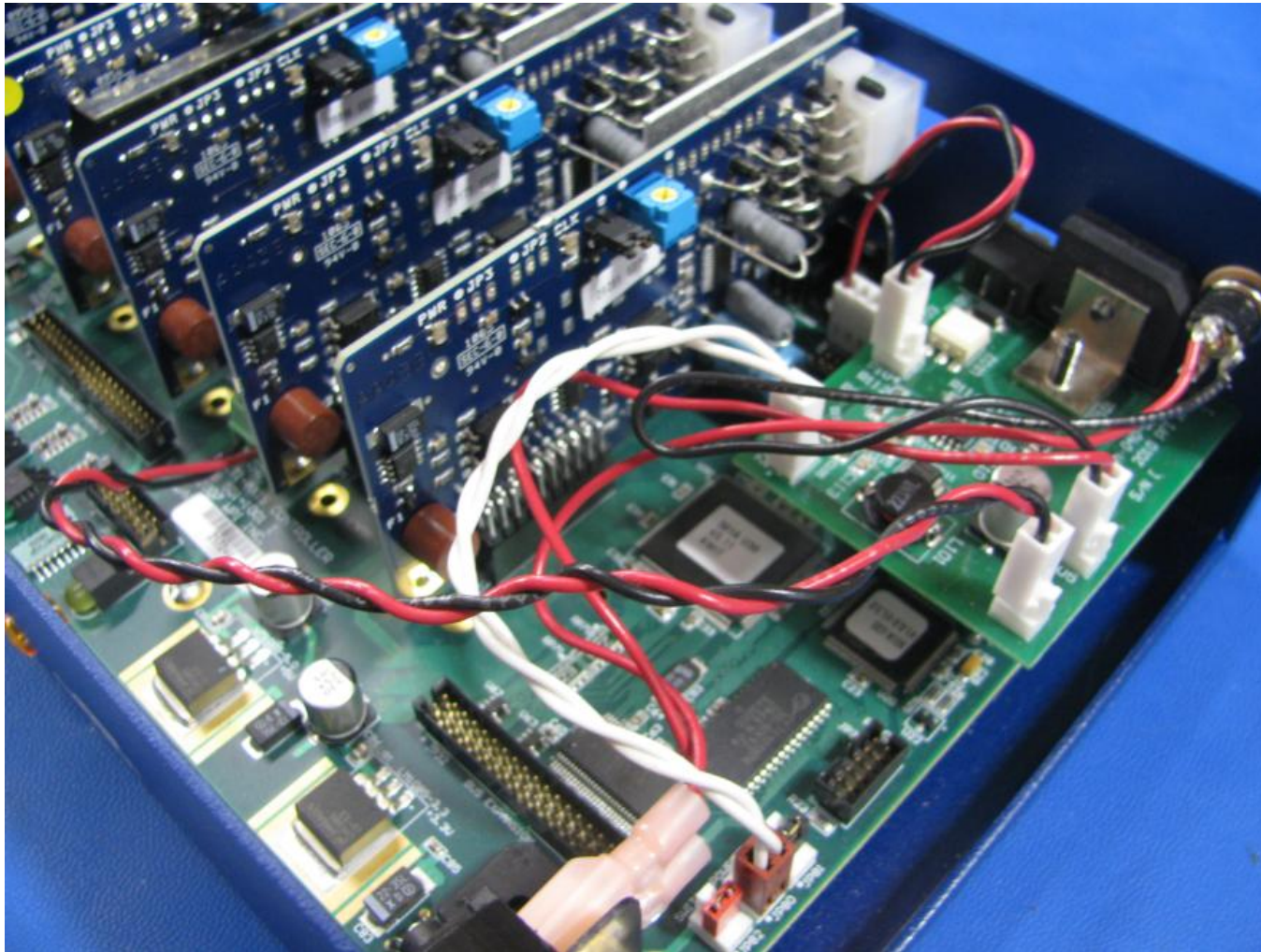

Connection Schematic

