

# TECHNICAL BULLETIN – 4X00/TMX/5100: 2020 Model Upgrade Instructions

**Breakaway Information:** The new breakaway hosts several advantages over the old style breakaway. It still uses a magnetic style to hold the torch in place, but the switch has been updated and the assembly uses less maintenance. The laser plate finder feature allows a dot to be projected onto the surface of the material to easily locate plate origins, perform plate alignments, and trace parts to verify they will fit on material prior to cutting..

**Please Note:**

- It is recommended that you remove the platemarker (if installed) to access all necessary hardware and cabling easily.
- Removing the retaining cap and consumables from the torch will make the installation process easier.



**Required Tools:**

- 1/8" Allen Key
- 5 mm Allen Key
- 9/64" Allen key
- Side Cutters

**Remove the Breakaway and Laser from the packaging and verify the contents included:**

Quantity:	Description:	Part Number:
1	Updated Breakaway	TMS-101-5000-14 or TMS-101-5000-15
1	Breakaway Harness	TMS-402-0080-02
1	Ground Wire	TMS-402-0098-00 or TMS-402-0099-00
1	Adhesive Block for Securing Yoke	TMS-418-0000-00
1	Laser Pointer Assembly	TMS-101-4000-00 or TMS-101-4008-00
1	Laser Pointer Power Cable	TMS-101-4013-00 or TMS-101-4014-00

Updated on: 8/4/2020

TORCHMATE TECHNICAL SUPPORT: 866-571-1066  
www.torchmate.com

© Lincoln Global Inc. All Rights Reserved.



Cutting  
Systems

Page 1 of 13

US10-052720MA1-03

**Step 1:**

Turn the torch clamps counter clock-wise to loosen them and remove the torch from the torch clamps. Place the torch nearby.

**Please Note:** Removing the retaining cap and consumables from the torch makes this process easier.

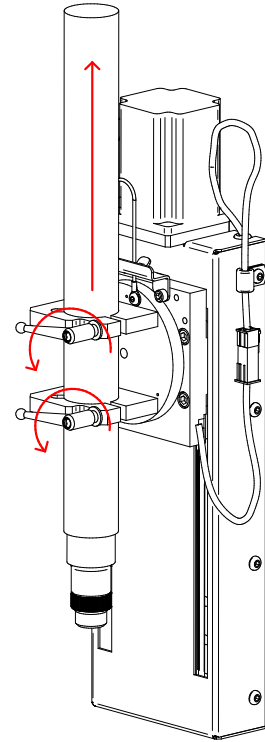

**Step 2:**

Remove the P-Clamp with a 1/8" Hex Key.

Discard the P-Clamp and re-install the screw.

**Step 3:**

Disconnect the 4 PIN MOLEX CONNECTOR.

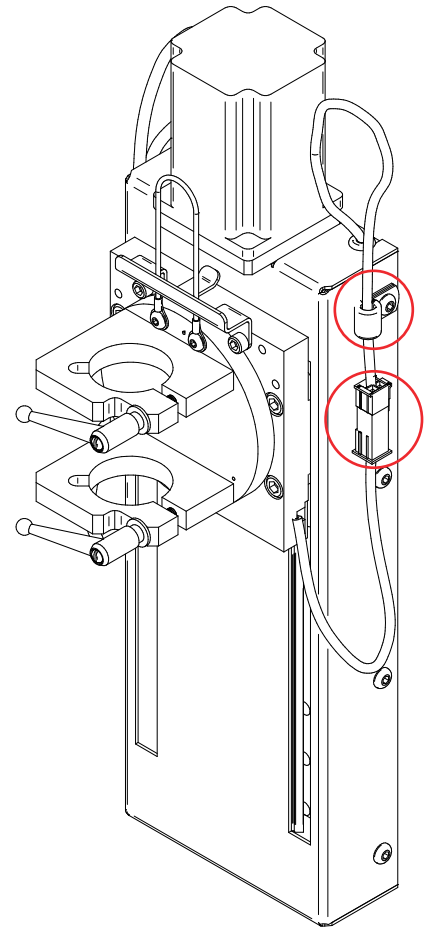

**Step 4:**

Remove the two P-Clamps on the left-hand side of the breakaway with a 1/8" Hex Key.

Save the top P-Clamp (the larger one) and discard the bottom P-Clamp (the smaller one). Re-install the bottom screw.

DO NOT UNPLUG THE Z MOTOR CABLE.

Next, unplug the 3P DIN CONNECTOR.

Set the MALE 3P DIN CABLE behind the lifter.

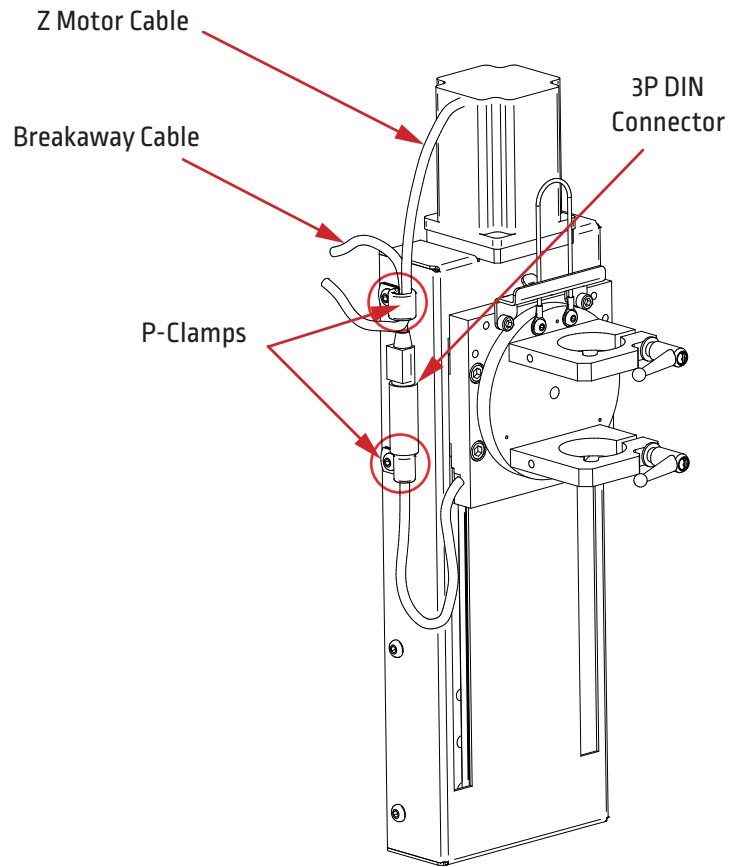

**Step 5:**

Decouple the breakaway to gain access to the mounting bolts.

Discard the steel puck/torch clamp assembly.

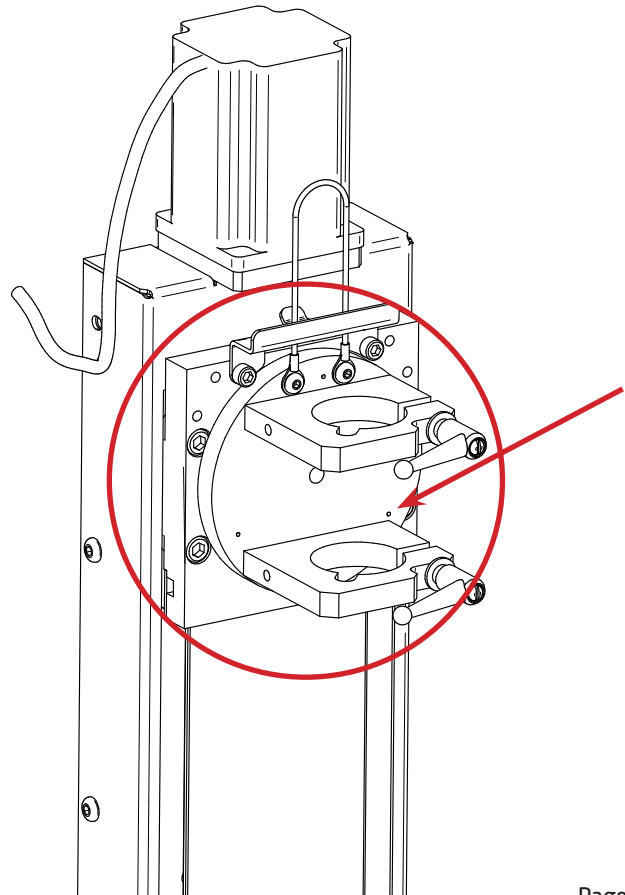

Updated on: 8/4/2020

TORCHMATE TECHNICAL SUPPORT: 866-571-1066  
www.torchmate.com

© Lincoln Global Inc. All Rights Reserved.



**Cutting  
Systems**

Page 3 of 13

US10-052720MA1-03

**Step 6:**

Remove the breakaway base plate by disconnecting the (4) M6 screws with a 5 mm Allen Key.

Do not discard the screws.

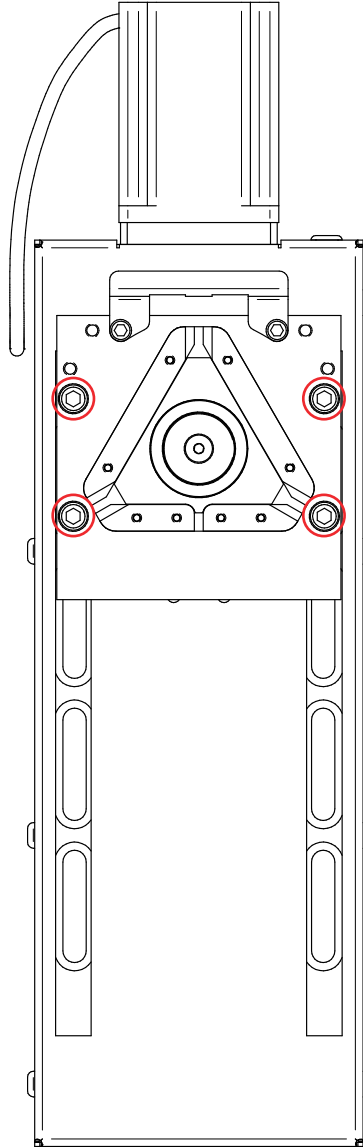

Updated on: 8/4/2020

TORCHMATE TECHNICAL SUPPORT: 866-571-1066  
[www.torchmate.com](http://www.torchmate.com)

© Lincoln Global Inc. All Rights Reserved.



Page 4 of 13  
**Cutting  
Systems**

US10-052720MA1-03

**Step 7:**

Remove the new breakaway from its packaging.

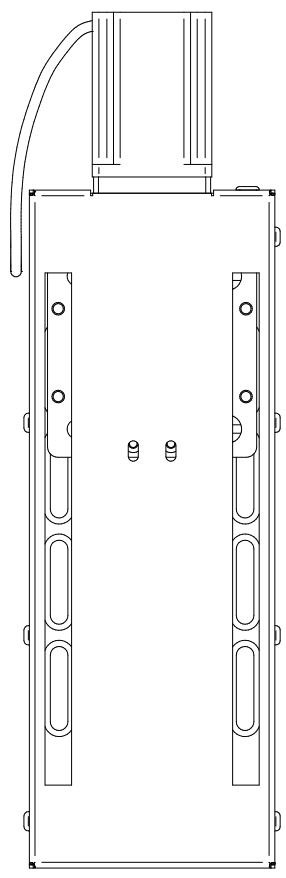
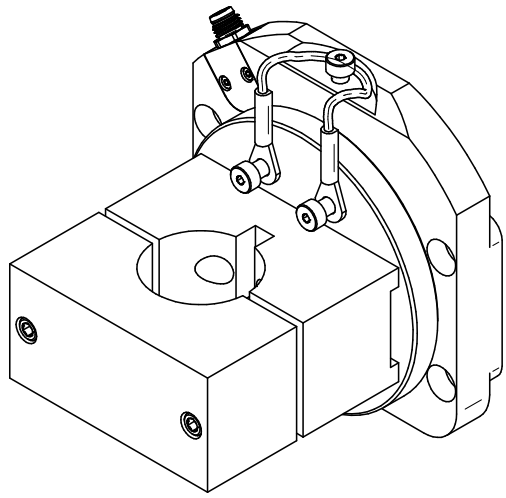

**Step 8:**

Install new breakaway with M6 screws.

A 5 mm Allen Key is required to install the screws.

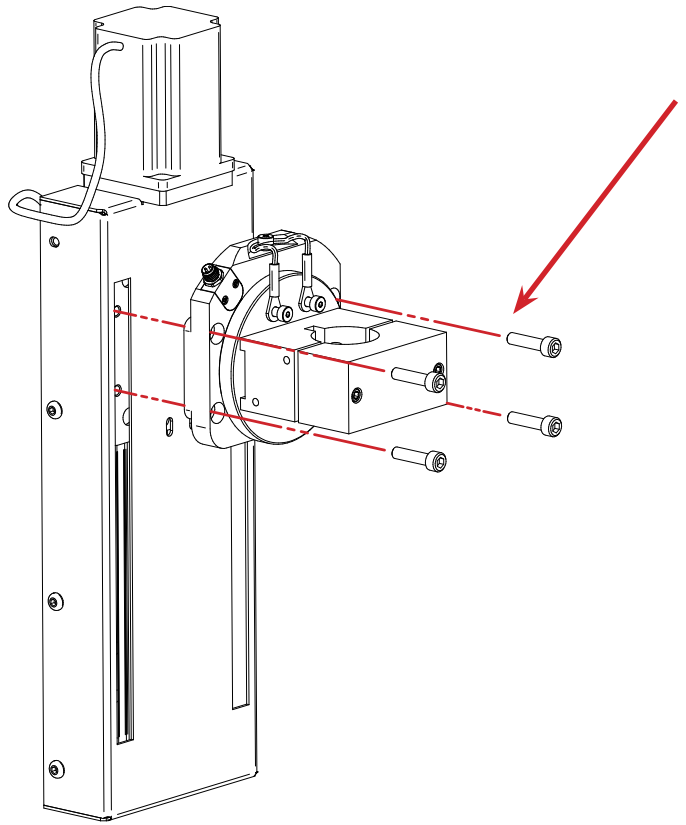

Updated on: 8/4/2020

TORCHMATE TECHNICAL SUPPORT: 866-571-1066  
www.torchmate.com

© Lincoln Global Inc. All Rights Reserved.



Page 5 of 13

**Cutting  
Systems**

US10-052720MA1-03

**Step 9:**

Install the laser housing onto the new laser arm.

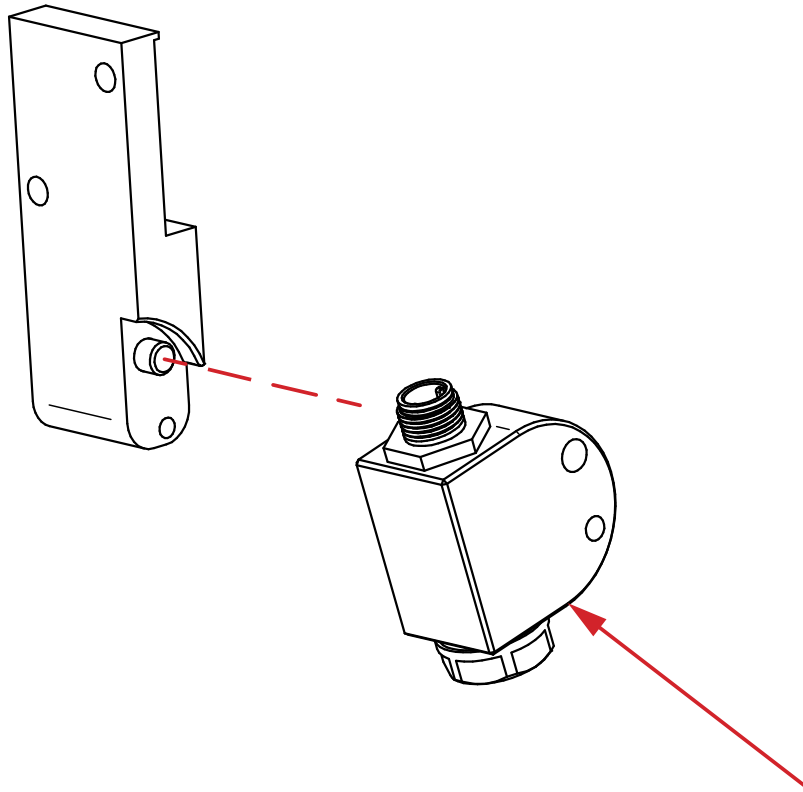

**Step 10:**

Use a 1/8" Allen Key to install the # 10-32 screw to secure the laser housing into the new laser arm.

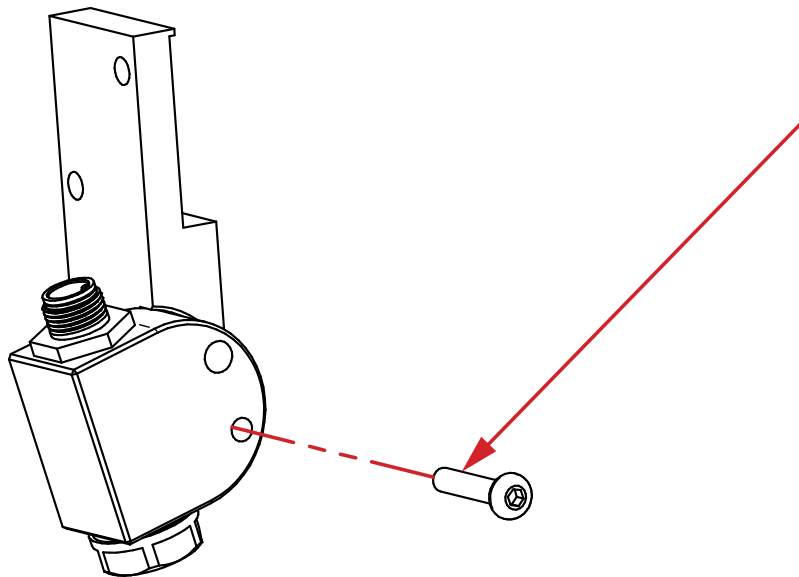

Updated on: 8/4/2020

TORCHMATE TECHNICAL SUPPORT: 866-571-1066  
[www.torchmate.com](http://www.torchmate.com)

© Lincoln Global Inc. All Rights Reserved.

**LINCOLN**  
**ELECTRIC**

**Cutting  
Systems**

Page 6 of 13

US10-052720MA1-03

**Step 11:**

Using the 2 # 10-32 screws included, install the Laser Pointer Accessory onto the Torch Breakaway as shown.

Leave the screws finger tight.

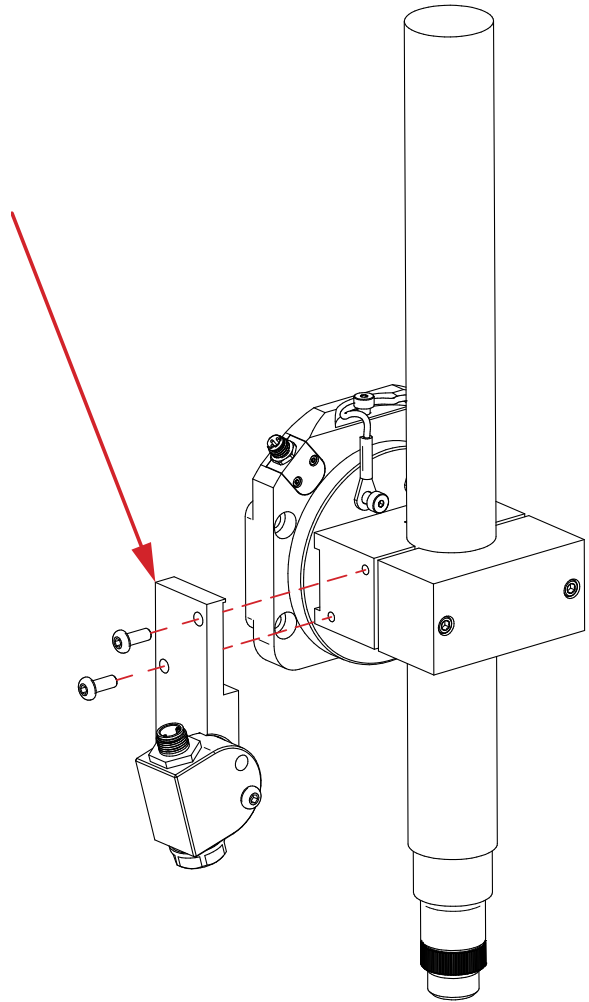

**Step 12:**

Verify that the locating edge of the laser arm is resting on the top surface of the torch clamp, and using a 1/8" Allen key tighten the # 10-32 screws

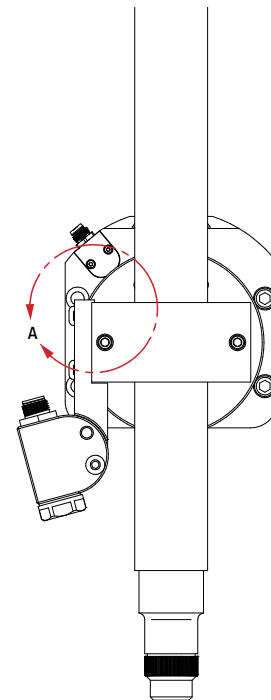
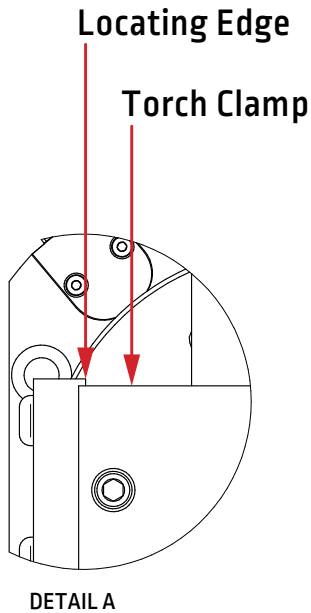

Updated on: 8/4/2020

TORCHMATE TECHNICAL SUPPORT: 866-571-1066  
www.torchmate.com

© Lincoln Global Inc. All Rights Reserved.

**LINCOLN**  
**ELECTRIC**

**Cutting  
Systems**

Page 7 of 13

US10-052720MA1-03

**Step 13:**

Plug in the M8 CONNECTOR from the new breakaway harness.  
Tighten to finger tight.

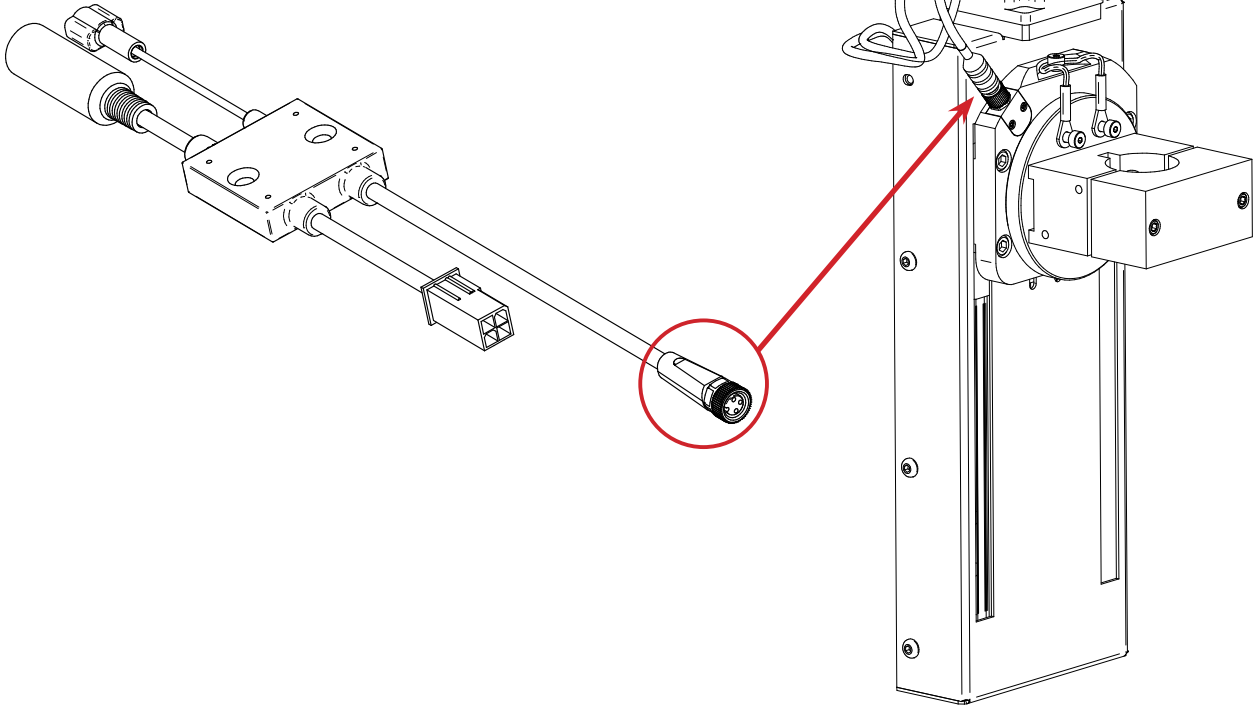

**Step 14:**

Use a 1/8" Allen Key to re-install the large P-Clamp with the Z motor cable and the breakaway cable inside of it. Match the clamp orientation shown in the drawing.

Verify adequate cable length is present by pushing the Z lifter to the bottom of its travel.

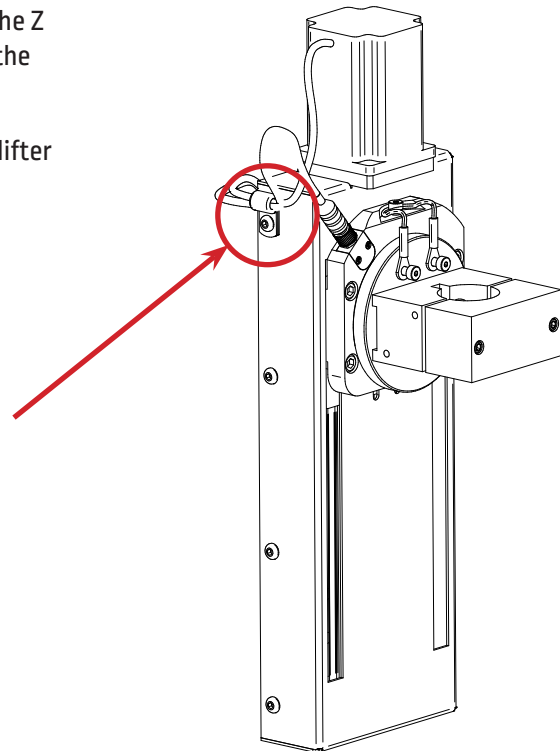



**Step 15:**

Plug the MOLEX CONNECTOR from the Z Lifter into the new breakaway harness.

**Please Note:** Route the Z Datum Cable behind the lifter.

DO NOT attach this cable to any of the moving parts of the Z Lifter Station.

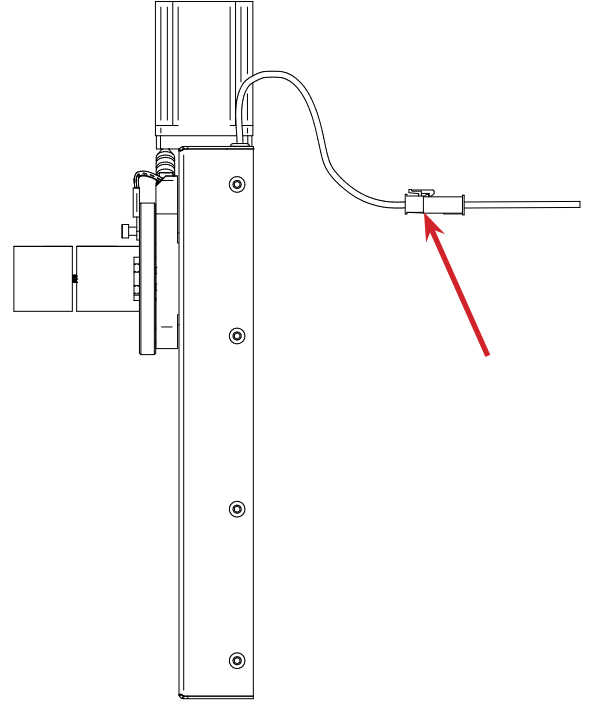
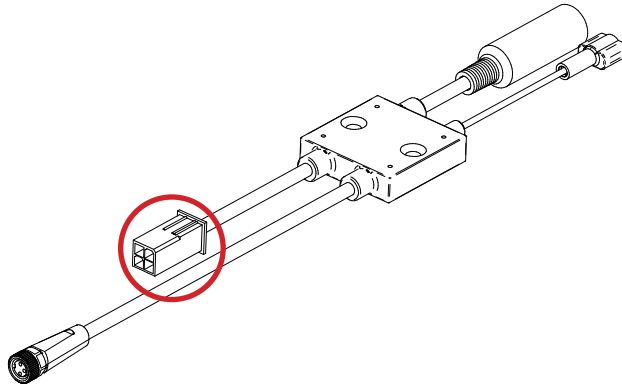

**Step 16:**

Plug existing breakaway cable into new breakaway harness.

Excess breakaway cable can be doubled back into the cable carrier.

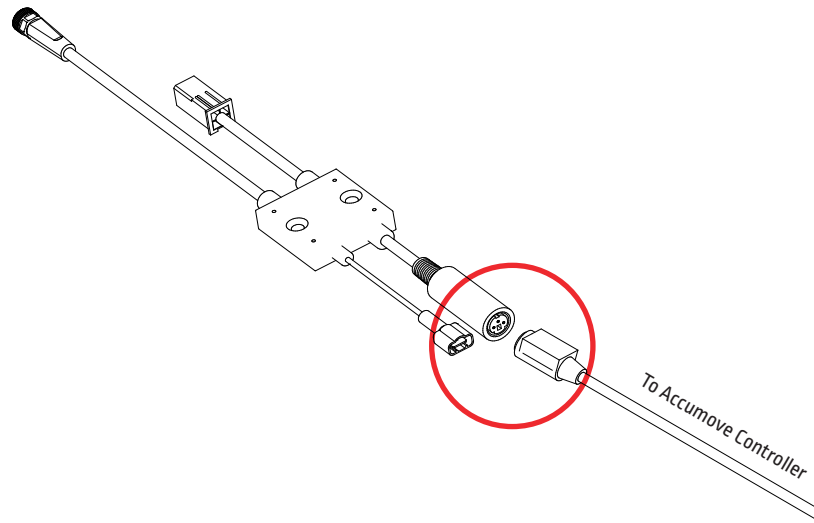

**Step 17:**

Install the ground lead and laser power cable into the cable carrier along the motion control cables. Remove zip ties at the beginning and ending strain relief points and install new zip ties, ensuring that there is some slack of the cables in the carrier to allow for the cables to move freely. Pass the laser power cable through the cable pass through along with the rest of the cables, it will be terminated in the next step.

Connect the ring terminal to the star ground and connect the QD terminal to the new breakaway harness.

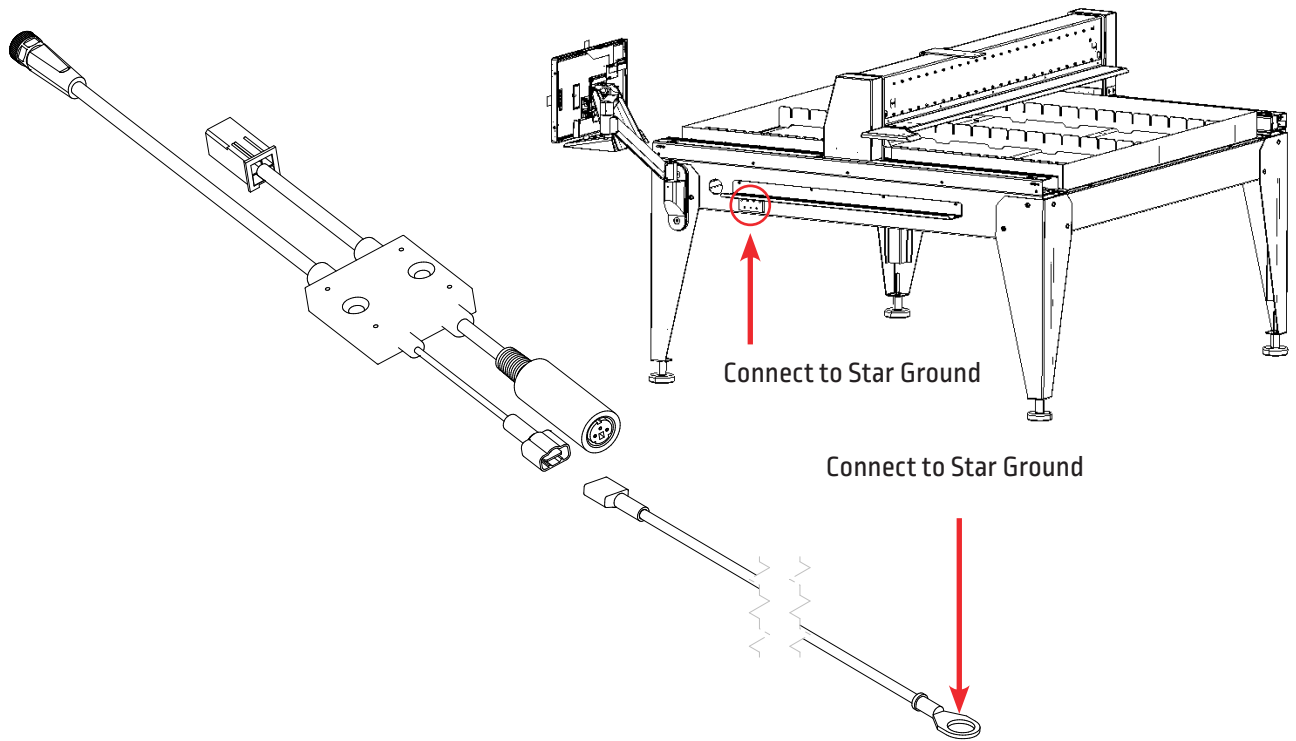

**Step 18:**

Connect the M12 connector of the laser power cable to the laser puck on the breakaway, and plug the two pin terminal strip into output #3 on the back of the Accumove controller. These connectors are keyed and can only be plugged in one way.

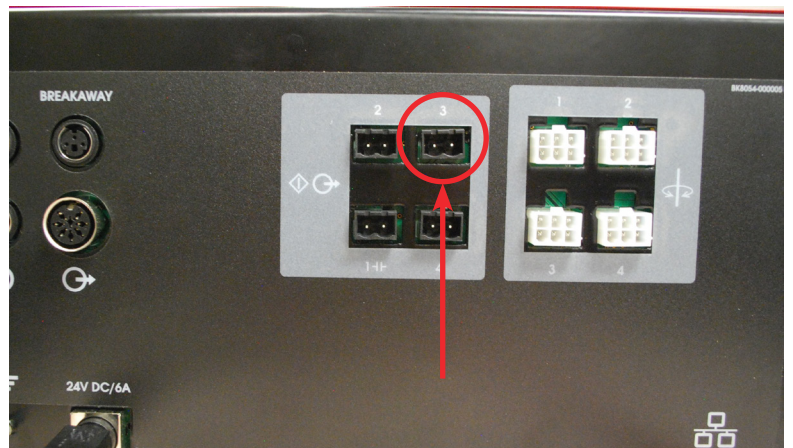
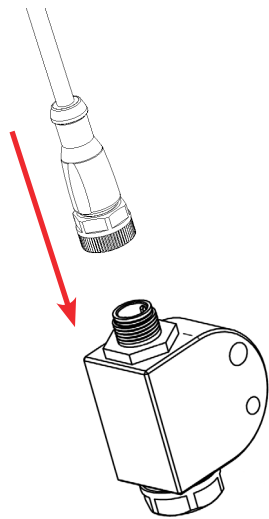

**Step 19:**

Install the torch into the clamps.

A 9/64" allen key is required to tighten the screws on the clamps, snug the bolts to the point where the torch does not fall freely but can be manipulated up and down.

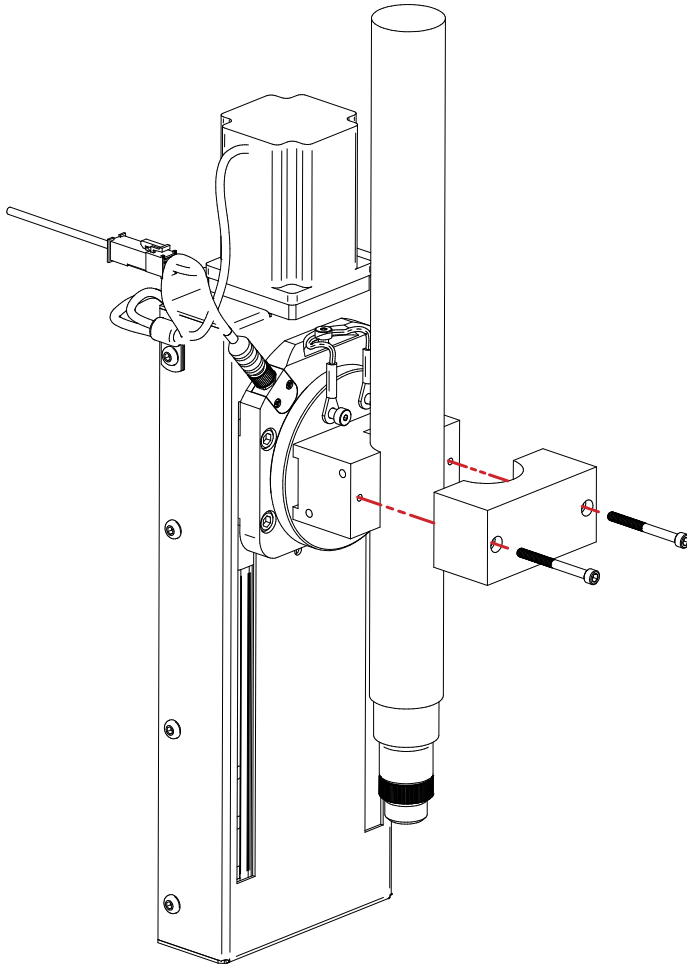

**Step 20:**

Depending on the model of your machine, the Z Lifter mounting position and torch tip stickout amount may need to be adjusted.

If this step is not completed, the Laser Pointer accessory may not function as intended.

Use the following table to adjust the lifter mounting height and torch tip stickout.

Typical values for torch tip stickout are shown. Correct torch tip stickout can be verified by datuming, moving the Z axis to -6.625", and confirming that the torch is at or below the slat surface.

Supported Machine Types	Lifter Mounting Height	Torch Tip Stickout
4400 & 4800	3.900 +/- 0.125	6.261
Torchmate X	6.000 +/- 0.125	8.324
5100 Downdraft	5.000 +/- 0.125	7.32
5100 Water Table	7.000 +/- 0.125	9.324

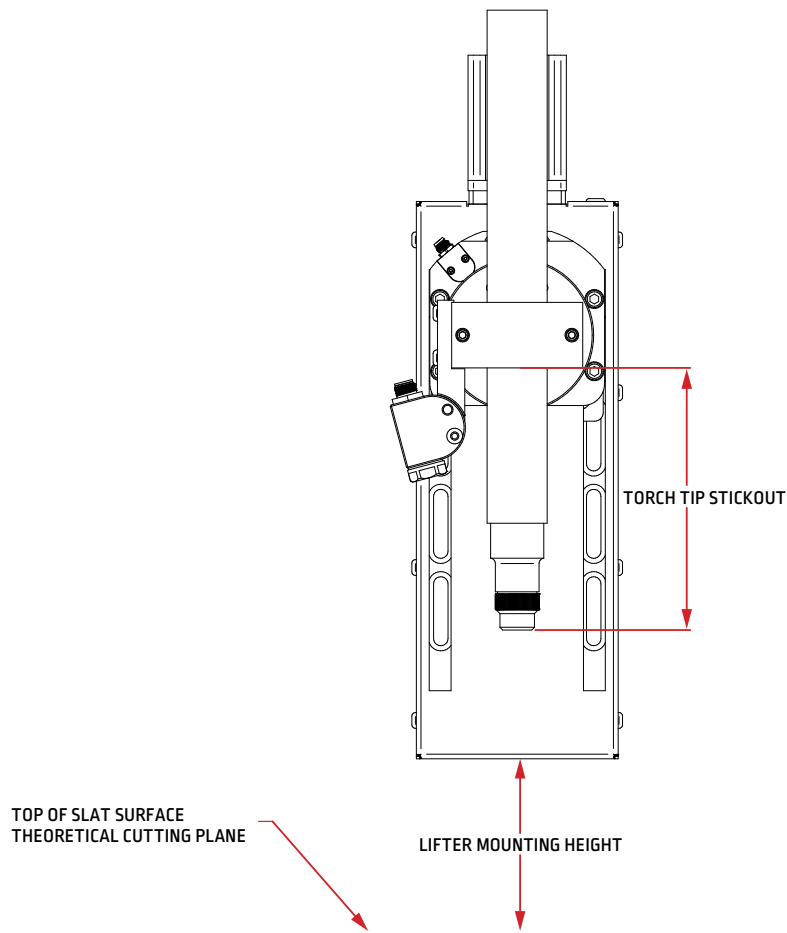

Updated on: 8/4/2020

TORCHMATE TECHNICAL SUPPORT: 866-571-1066  
[www.torchmate.com](http://www.torchmate.com)

© Lincoln Global Inc. All Rights Reserved.



**Cutting  
Systems**

Page 12 of 13

US10-052720MA1-03

**Step 21:**

If your machine is currently running a software version older than 4.8.6.0 then the software must be updated to enable the laser option and onboard cut charts. To determine which version of the VMD software your machine is operating on, in the VMD software log on as an Admin, the password is 1234. At the top, center of the screen the software version is displayed.

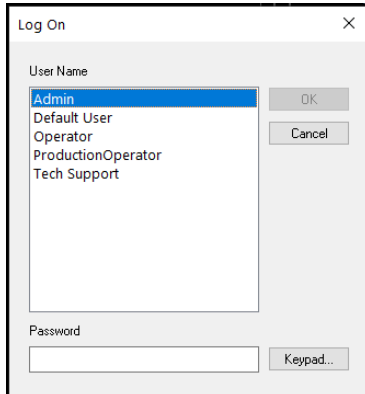

Visual Machine Designer [4.8.6.0] - [Run.wap]

If the software version displayed is lower than 4.8.9.2, then download the latest Service Pack 2 installation at the link below.

**DOWNLOAD HERE**