

# NEVER plug in cables while device is powered on!

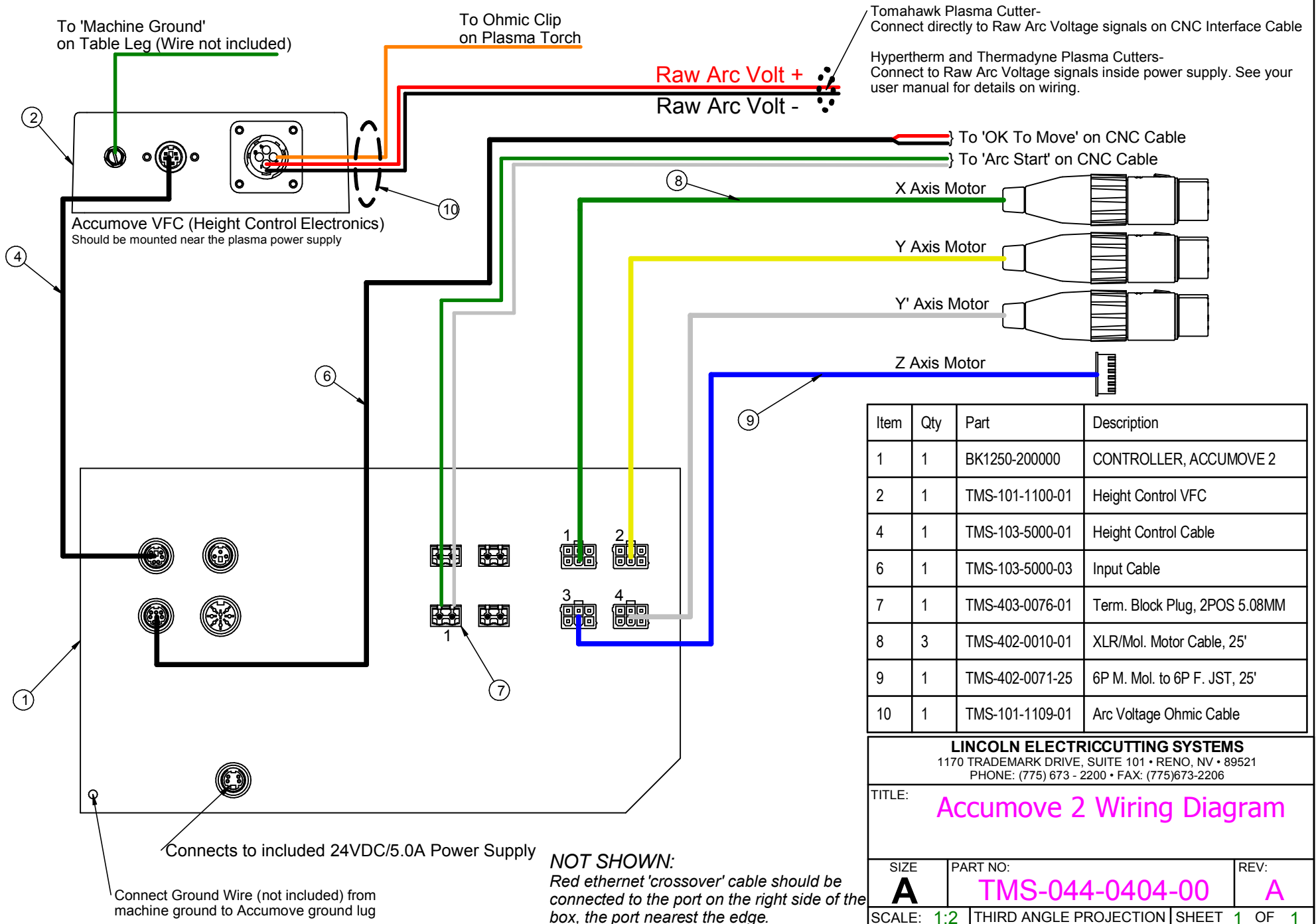

Tomahawk Plasma Cutter-  
Connect directly to Raw Arc Voltage signals on CNC Interface Cable

Hypertherm and Thermadyne Plasma Cutters-  
Connect to Raw Arc Voltage signals inside power supply. See your user manual for details on wiring.

Item	Qty	Part	Description
1	1	BK1250-200000	CONTROLLER, ACCUMOVE 2
2	1	TMS-101-1100-01	Height Control VFC
4	1	TMS-103-5000-01	Height Control Cable
6	1	TMS-103-5000-03	Input Cable
7	1	TMS-403-0076-01	Term. Block Plug, 2POS 5.08MM
8	3	TMS-402-0010-01	XLR/Mol. Motor Cable, 25'
9	1	TMS-402-0071-25	6P M. Mol. to 6P F. JST, 25'
10	1	TMS-101-1109-01	Arc Voltage Ohmic Cable

**LINCOLN ELECTRIC CUTTING SYSTEMS**  
1170 TRADEMARK DRIVE, SUITE 101 • RENO, NV • 89521  
PHONE: (775) 673 - 2200 • FAX: (775) 673-2206

TITLE: **Accumove 2 Wiring Diagram**

SIZE <b>A</b>	PART NO: <b>TMS-044-0404-00</b>	REV: <b>A</b>
SCALE: 1:2	THIRD ANGLE PROJECTION	SHEET 1 OF 1

**NOT SHOWN:**  
Red ethernet 'crossover' cable should be connected to the port on the right side of the box, the port nearest the edge.