













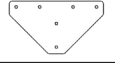

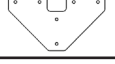
Qty.	Label	Part	Description	Part Number	Step
8	A		Water table leg,	TMS-130-0004-23-B	1
8	K		Leveling foot, ½-13 Deluxe 4"	TMS-448-0004-04	1
16	E		Water table gusset, 45-deg	TMS-130-0004-32-A	2
240	L		Screw, ⅝- 18 X ¾ SHCS INCLUDED IN PART KIT	TMS-410-0016-12 (TMS-130-0004-45)	2, 3, 4, 5, 6, 7, 8, 9, 10
240	M		Lockwasher, ⅝ high collar INCLUDED IN PART KIT	TMS-413-0501-16 (TMS-130-0004-45)	2, 3, 4, 5, 6, 7, 8, 9, 10
16	G		Water table gusset, 180-deg	TMS-130-0004-34-A	3, 7, 9
18	B		Water table cross brace, length, 32.562"	TMS-130-0004-28-A	4, 7, 9
8	F		Water table gusset, 45-deg relieved	TMS-130-0004-33-A	5
8	H		Water table gusset, 180-deg relieved	TMS-130-0004-35-A	5
4	C		Water table shelf support, 51"	TMS-130-0004-27-A	6
4	D		Water table cross brace, width, 55"	TMS-130-0004-26-A	8
16			Drop in T-Nut INCLUDED IN PART KIT	TMS-440-0024-01 (TMS-130-0004-45)	11
4	I		TM Legacy joining bracket	TMS-130-0004-36-A	12
16			T-bolt INCLUDED IN PART KIT	TMS-410-5016-10 (TMS-130-0004-45)	12
16			T-nut INCLUDED IN PART KIT	TMS-414-1301-16 (TMS-130-0004-45)	12
1	J		Water table water pan assembly 4x8	TMS-130-0004-49	13
1	1		TFP-AR small table ¾ plumbing (water release valve)	TMS-459-0010-01	13
1	1		PTFE thread-sealant tape (recommended)	(separate purchase)	13

Torchmate Classic Water Table Quick Start Guide

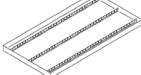
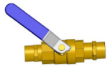

Cutting Systems

FOR COMPLETE ASSEMBLY INSTRUCTIONS PLEASE LOCATE YOUR USB DRIVE

This quick start guide is not intended to replace the complete assembly guide for this product. Please refer to the complete assembly instructions found in the provided USB thumb drive. Before you start construction please make sure that all parts have been shipped in satisfactory condition. A parts list is located on the back page of this quick assembly guide.

4x8

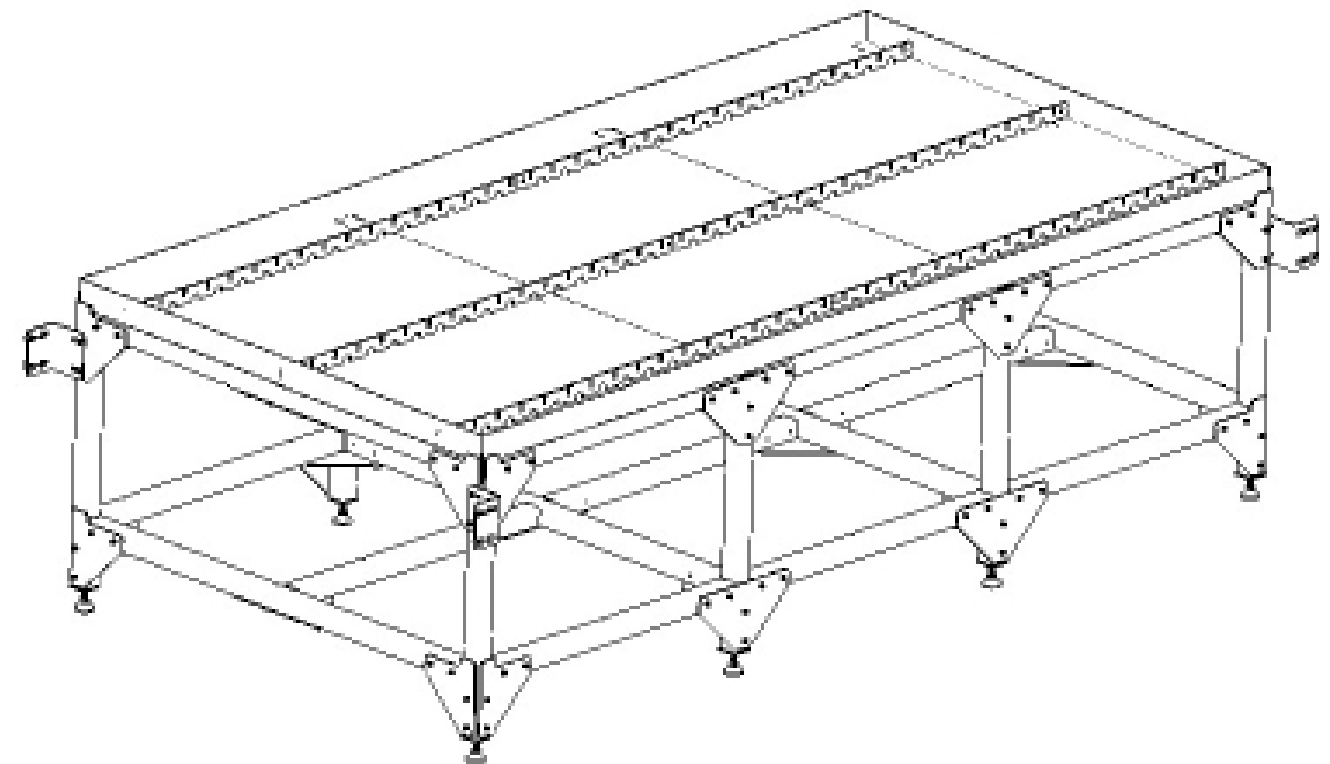

Need Help?

Call TORCHMATE TECHNICAL SUPPORT:
866-571-1066 to talk to a
Technical Support Representative

Hours of Operation:
6:00 AM to 4:00 PM (PT) Mon. thru Fri.
(0600 to 1600)

After Hours:
Send a detailed email message to:
support@torchmate.com

For service outside the USA:
Call 775-673-2200 or send an email to
support@torchmate.com

SCAN ME FOR DIGITAL ACCESS TO
THE COMPLETE ASSEMBLY GUIDE

PASSWORD = WELDRED (ALL CAPS)



www.torchmate.com

TMS-011-0041-12

© Lincoln Global Inc. All Rights Reserved.

Updated on: April 18, 2016



775-673-2200 TECH SUPPORT
ONLINE CHAT TORCHMATE.COM

- The cutting table is assembled in a series of easy steps.
 - Step 1: Add leveling feet to legs
 - Step 2: Add gussets to corner legs
 - Step 3: Add gussets to middle legs
 - Step 4: Assemble sides with legs and cross braces
 - Step 5: Add horizontal gussets to sides
 - Step 6: Add shelf supports to one side
 - Step 7: Add shelf support gussets and cross braces
 - Step 8: Add water pan width support cross braces
 - Step 9: Add water pan mid-width gussets and cross braces
 - Step 10: Add the second side
 - Step 11: Level table and tighten all screws
 - Step 12: Position water table inside pre-built cutting table (if necessary)
 - Step 13: Add joining brackets and attach to cutting table
 - Step 14: Lower water pan into table and add slats

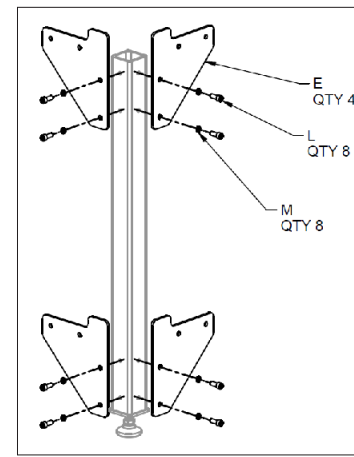

Step 1-2

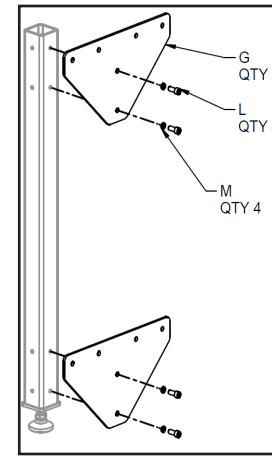

Step 3

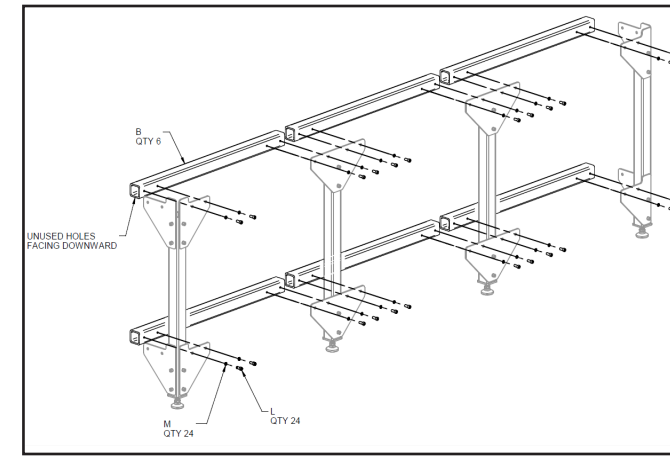

Step 4

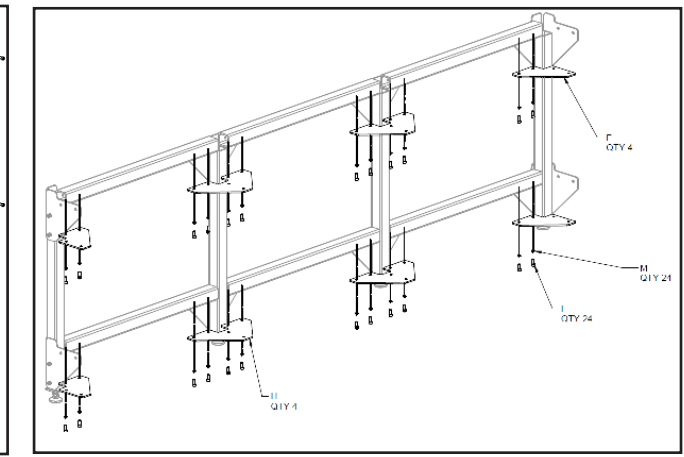

Step 5

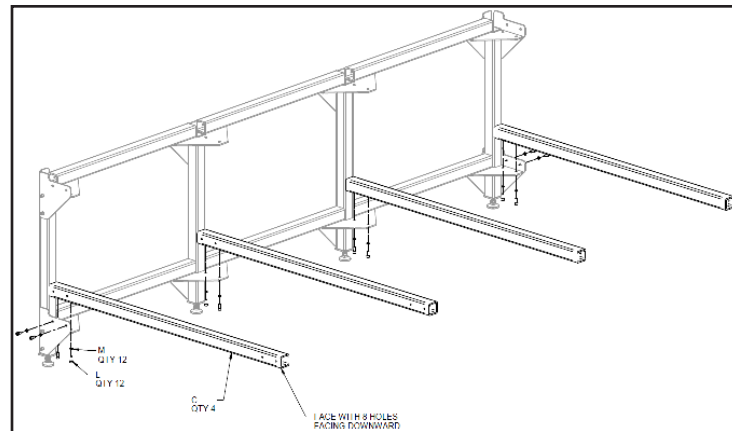

Step 6

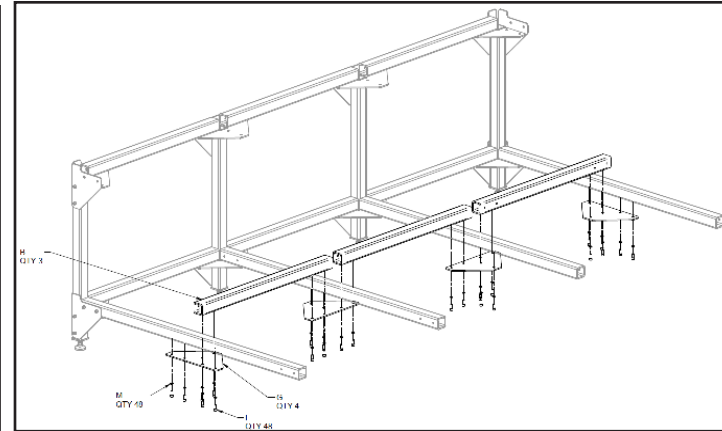

Step 7

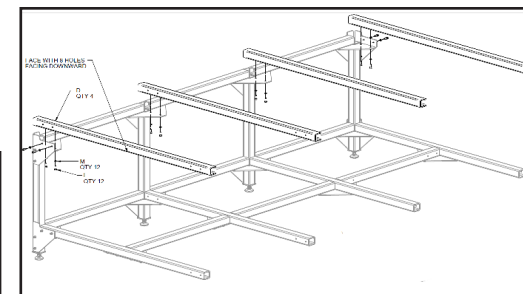

Step 8

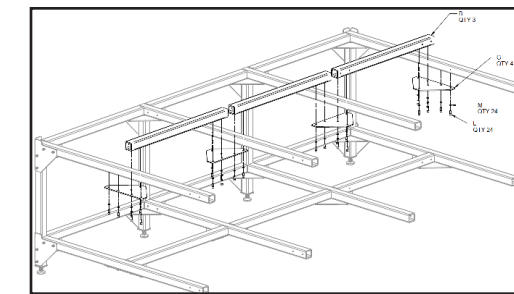

Step 9

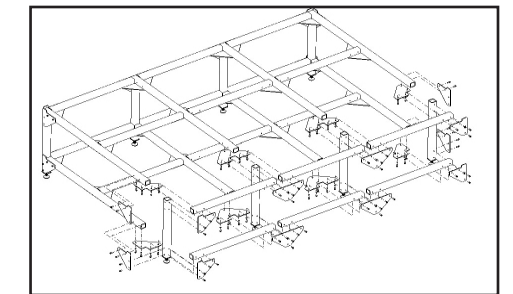

Step 10-11

Step 11 bracket may be installed after table has been positioned inside CNC table assembly.

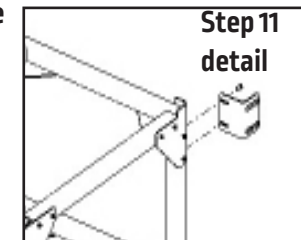

Step 11 detail

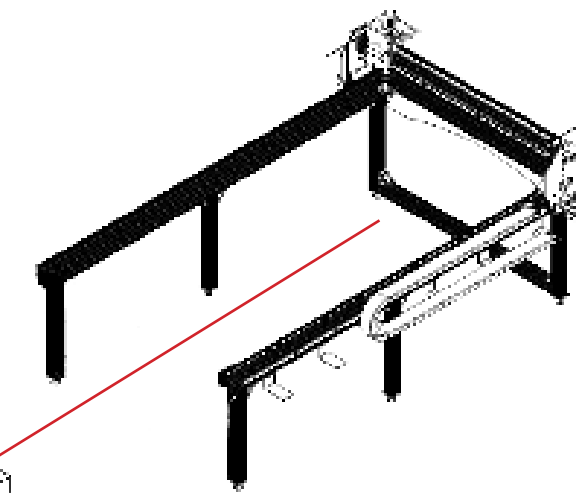

Step 12-14

Customer must supply:
 (35) consumable slats
 53 1/2" long X 2" wide x 3/16 thick

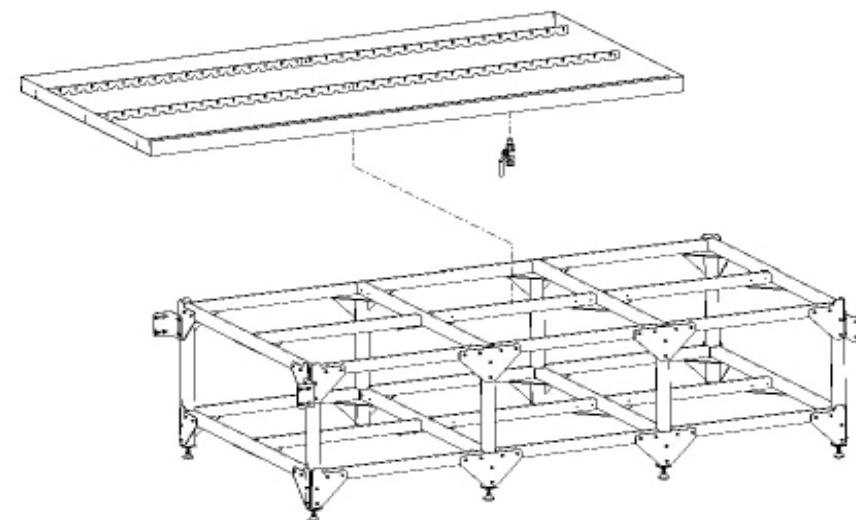

Important Grounding Information
 Customer supplied earth ground must be provided. The center slat support has been left raw in order to provide a grounding location.
 Please refer to the CNC table instruction.
 For more information on EMI reduction and proper grounding please visit:
<http://torchmate.com/white-papers/EMI-Reduction>

www.torchmate.com

© Lincoln Global Inc. All Rights Reserved.

Updated on: April 18, 2016